

 **TECNOSEAL**
save your dreams

A N O D I S Pleasure Craft Catalogue 2 0 1 1



ANODI

CATALOGO NAUTICA 2011

Vorrei spendere alcune parole sul catalogo TECNOSEAL che è col tempo diventato per noi e per i nostri clienti un vero e proprio vademecum, un manuale fondamentale per districarsi nella miriade di anodi differenti utilizzati dai cantieri di costruzione Europei e Americani e dai produttori di motori, di linee d'asse e altri componenti.

Anche per questa edizione 2009 ho il piacere di annunciare che il nostro team tecnico e commerciale è riuscito ad arricchire la nostra offerta di oltre 20 nuovi tipi di anodi. Tale sforzo nelle intenzioni dell'azienda è teso a soddisfare le alte aspettative di completezza e di aggiornamento che i nostri clienti di fiducia ci onorano di riporre in Tecnoseal.

I nuovi prodotti, oltre ad alcuni recentissimi anodi motore, si riferiscono a piastre per lo scafo e flangie utilizzate da cantieri di costruzione Americani e Inglesi. Tutto questo fatto mi dà il la per formulare i miei migliori auguri allo staff della nostra gemella Tecnoseal USA che ha iniziato nel 2007 con grandi ambizioni nella distribuzione e vendita dei nostri anodi Made in Italy dalla sua sede in Florida.

Un altro prodotto/servizio che troverete, in cui personalmente credo molto e che voglio segnalare con viva attenzione, sono i kit degli anodi motore (Volvo e Mercury). Anche per quanto riguarda il packaging del prodotto Tecnoseal vuole essere attenta a seguire le nuove esigenze e nuove richieste del mercato.

Sempre in quest'ottica una novità che ci auguriamo gradita ai nostri clienti è rappresentata dall'introduzione dei codici a barre associati ai nostri prodotti. Questi dovrebbero facilitare i flussi logistici degli ordini in tutta la catena distributiva orientata ormai ad una informatizzazione dei processi sempre più spinta.

Concludo ringraziando gli amici clienti e i ragazzi del "team Tecnoseal" per il percorso fatto assieme in questi anni con la stima e l'immane supporto reciproco. Ancora molta strada che ci attende da fare con lo stesso crescente entusiasmo.

Per ultimo una parola alla mia famiglia, la cui continuità generazionale da sempre e sempre sarà custode della qualità del Made in Italy dei nostri prodotti nel mondo. Per questo un sincero ringraziamento a mio padre Emilio, di cui Tecnoseal rispetta i principi ed i valori, e un augurio particolare di futuro radioso con tutti voi a mio figlio Gioele. Grazie di cuore.

Cap. Silvestro Scotto



I would like to say a few words about our 2009 catalogue that has become through the years for us and for our customers a real vademecum, a fundamental handbook for the right understanding of the so many different anodes used by the American and European shipyards and also by the producers of engines, shafts and other items.

Also for this edition, I am pleased to announce that our technical and sales team succeed in offering 50 new types of anodes in order to get the most possible complete range and to be able to answer the needs of our customers in the best way.

The new products, besides some of the most updated engines anodes, are some plates for hull and rudders especially used by American and English shipyards. I take this occasion to wish all the best to the staff of our sister company Tecnoseal USA which started in 2007 from its office in Florida the distribution and sales of our anodes made in Italy.

Another new product/service in which I really believe is the Anodes Kit (Volvo and Mercury). Tecnoseal wants to take particularly care to the anode packaging and to adapt itself to the new requests of the market.

Always searching to answer the market's needs and to serve our customers in the best way, we introduced this year the barcode system which should make easier our whole logistic and our distribution chain. This process modernization will optimize the service we provide to our clients.

As a conclusion, I would like to thank our customers and partners but also the whole "Tecnoseal team" for the cooperation during these years, only possible thanks to our mutual esteem and support and I really hope that the enthusiasm will be the same during the forthcoming years.

A last word to my family who is for generations the guarantor of the quality Made in Italy of our products around the world. For that reason, I sincerely thank my father Emilio, who gave his principles and values to Tecnoseal and I wish a nice future with all of you to my son Gioele. Thank you so much.

Captain Silvestro Scotto



TECNOSEAL SRL è uno dei leader mondiali nel campo della protezione catodica applicata alla nautica e alle installazioni navali, offshore e industriali. Con oltre 30 anni di esperienza produciamo e vendiamo dalla nostra sede di Grosseto in Toscana anodi sacrificali di Zinco, Alluminio e Magnesio con la passione che ci contraddistingue volta alla continua ricerca della perfezione nella qualità del prodotto e nel servizio ai clienti. Iniziata negli anni 70 come un'attività artigianale dalla famiglia Scotto adesso la Tecnoseal vanta probabilmente il range di anodi per la nautica più vasto a livello mondiale con poco meno di 1000 anodi a catalogo e oltre 3000 altri articoli prodotti su misura per i clienti.

TECNOSEAL SRL is one of the world leading suppliers of sacrificial anodes for cathodic protection in the leisure boat market and for shipping, offshore and industry different application. With over 30 years of experience, we produce and supply from our foundry in Grosseto (Tuscany) Zinc, Aluminum and Magnesium anodes with our own peculiar passion for seeking the quality perfection of the product and the customer service. Started in the 70's by the Scotto family as an handicraft company, Tecnoseal srl has now one of the largest anodes range in the world with almost 1000 anodes in its standard catalogue and more than 3000 others articles realized on specific request of the customers.



LA FONDERIA E IL PRODOTTO

I nostri prodotti sono totalmente realizzati nella nostra fonderia di Grosseto, dalla progettazione degli stampi all'anodo finito e pronto per essere spedito al cliente. La qualità è garantita dall'efficacia dei processi e dall'esperienza e preparazione dei nostri specialisti tecnici.

Tra le fasi di eccellenza di questo ciclo lavorativo virtuoso possiamo menzionare: la progettazione degli stampi mediante CAD tridimensionale; il metodo estremamente preciso di stampaggio in pressofusione ottenuto grazie a macchinari di ultima generazione con alta tecnologia a controllo di processo dell'iniezione; il controllo sistematico della perfetta purezza della materia prima e della composizione della lega nel prodotto finito secondo gli standard internazionalmente accettati (come la specifica US MILA-18001); il controllo finale artigianale di ogni singolo pezzo e non ultimo un servizio di confezionamento customizzato.

Risultato di ciò è un prodotto finemente rifinito di eccellente qualità molto apprezzato nel mondo dai cantieri di nuova costruzione, rimessaggi e rivenditori di materiale nautico.

THE FOUNDRY AND THE PRODUCT

Our anodes are entirely manufactured in our Grosseto foundry, from the mould design to the final product. The anodes quality is guaranteed by the quality of the process and by the experience and preparation of our specialist Engineers.

As parts of this virtuous cycle we can mention: a 3D Cad assisted mould design stations, the extra fine die-casting production method with our last high generation technology, the systematic raw material purity analysis and alloy composition check on final product in accordance with the worldwide accepted standard (like US MILA-18001), the handmade final visual quality check and a customise packaging service.

The result of that is an highly valued, perfectly finished up product, excellent quality wise satisfacionally used and appreciated worldwide by boatbuilders, shipyards and marine equipment retailers.



REPARTO TECNICO

Per soddisfare le crescenti richieste di mercato e i bisogni dei nostri clienti in termini di sistemi di protezione catodica sempre più efficaci Tecnoseal ha creato negli ultimi anni al suo interno un reparto tecnico commerciale. I nostri ingegneri possono prestare un servizio personalizzato ai costruttori in ambito nautico e navale per la progettazione e disposizione della massa anodica, fornire lo schema di posizionamento e le istruzioni sull'installazione. I tecnici Tecnoseal possono inoltre offrire un supporto tecnico sul posto per controllare e diagnosticare problemi di corrosione su ogni tipo di imbarcazioni o strutture a mare come palancole, pontili, piattaforme offshore ed altre applicazioni industriali.

Tecnoseal per queste applicazioni è in grado di installare impianti di protezione catodica a corrente impressa di ultima generazione e sistemi di monitoraggio anche in remoto.

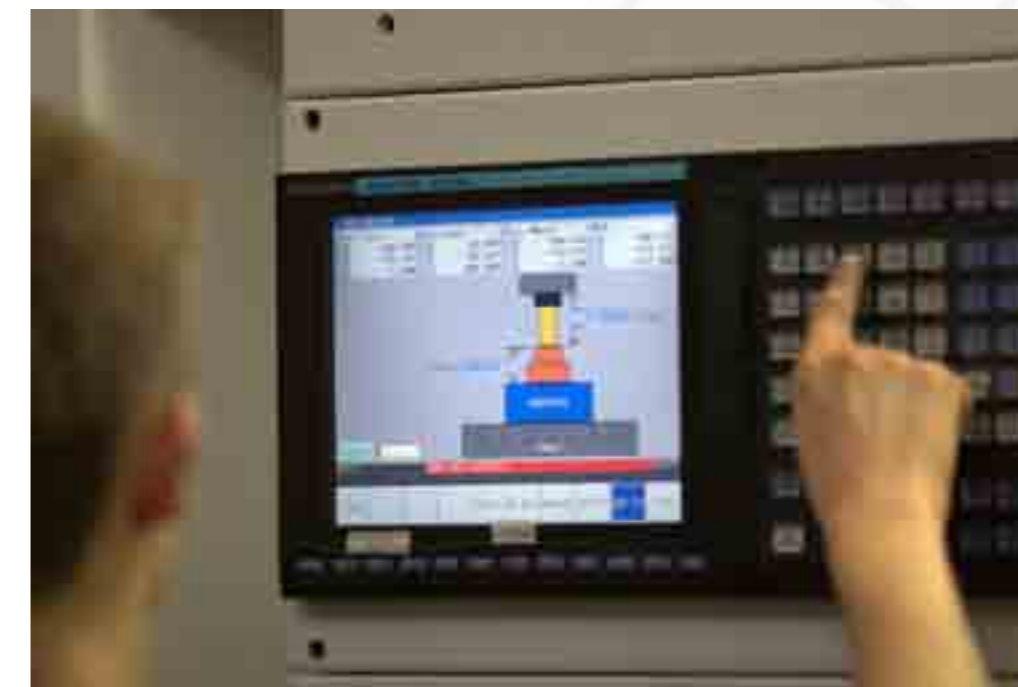

THE TECHNICAL DEPARTMENT

To satisfy the growing market requests and customers needs in terms of cathodic protection systems Tecnoseal has a dedicated technical department.

Our Engineers can provide a custom-made service to the boat builder designing the quantities, the positioning scheme and the installation instruction for the anodes system.

Our technicians can also offer a technical support on site for controlling corrosion problems occurring to any vessels or shoreline structures such as piling, jetties, platforms and pontoon systems. The Tecnoseal technical department provides and installs last generation impressed current cathodic protection systems and remote monitoring systems for harbors, platform of industrial application.

REPARTO COMMERCIALE

Il nostro ufficio gestione ordini gestisce direttamente in maniera precisa e puntuale i clienti direzionali e coordina una capillare rete di 12 agenzie in Italia e più di 30 distributori sparsi sui 5 continenti oltre alla società TECNOSEAL USA localizzata a Fort Lauderdale - Florida - USA.

Tecnoseal ha infatti investito importanti risorse per poter offrire sul mercato un range completo di prodotti, una qualità elevata, uno stock di anodi sempre disponibile per far fronte a consegne rapide degli ordinativi il tutto a prezzi competitivi. E' infatti nostra cura cercare di soddisfare con frequenti campagne promozionali anche le legittime esigenze e aspettative economiche della clientela.



THE SALES TEAM

Our sales staff is able to satisfy any customer need and request directly and throughout our sales network composed by 10 agents in Italy, our american branch in Fort Lauderdale - Florida (USA), the TECNOSEAL USA Company and more than 30 distributors worldwide.

We are offering the right compromise between affordable prices, best quality and fast delivery, we invest big resources to guarantee an high quality standard and to keep a wide stock of products always available. At the same time we are sensible to satisfy the economic expectation of our customers launching several promotional campaigns during the year.



THE CUSTOMER SERVICE

Our sales team takes care about the customers real needs, we are willing to be not merely a supplier but a reliable consultant and a friendly partner in the complex and sometime caothic marine and nautical market.

For that reason, our customer service is giving the best possible cooperation to each customer, following directly any request and providing with any detailed information about our products and its use but also giving after sales assistance.

CUSTOMER SERVICE

Il nostro customer service è estremamente attento ai bisogni reali dei clienti e ai rapidi cambiamenti del mercato. Nei confronti dei clienti non vogliamo solo essere uno dei tanti fornitori ma consulenti di fiducia e partner amichevoli nel complesso e mutevole mercato della nautica.

Per questo motivo riveste una notevole importanza il contatto continuo e diretto che vogliamo instaurare e mantenere con tutti i nostri clienti finalizzato a fornire informazioni, consulenze e chiarimenti su prodotti e il loro utilizzo sia in fase precedente all'ordine che nel postvendita.

Buon Catalogo a TUTTI!



Have a nice reading!

TABELLA DI CONVERSIONE • CONVERSION TABLE

<p>lunghezza • length 1 pollice (inch) = 25,4 millimetri 1 piede (foot) = 12 pollici = 30,48 centimetri 1 iarda (yard) = 3 piedi = 91,44 centimetri 1 miglio (naut. mile)marino = 1,853 chilometri</p> <p>velocità • speed 1 nodo (knot) = 1,853 km/h</p> <p>potenza • power 1 HP (horse power) = 1,014 CV = 0,746 KW 1 CV = 0,735 KW = 0,986 HP 1 KW = 1,36 CV = 1,34 HP 1 Kilocaloria/ora = 0,0012 KW = 0,0016 CV = 0,00156 HP</p> <p>peso • weight 1 grano = 0,06479 grammi 1 oncia=28,35 grammi = 437,4 grani 1 libbra = 16 once (oz) = 453,592 grammi</p> <p>temperatura • temperature F = (9/5) x C + 32 C = (5/9) x (F-32)</p>	<p>comparazione pollici/millimetri • comparison inch/millimeter 1/16 = 1,587 9/16 = 14,29 1/8 = 3,174 5/8 = 15,87 3/16 = 4,762 11/16 = 17,46 1/4 = 6,35 3/4 = 19,05 5/16 = 7,94 13/16 = 20,63 3/8 = 9,52 7/8 = 22,22 7/16 = 11,11 15/16 = 23,81 1/2 = 12,7</p> <p>multipli di pollice • multiple of inch 1" = 25,4 mm 4" = 101,6 mm 2" = 50,8 mm 5" = 127 mm 3" = 76,2 mm</p> <p>peso specifico (e temperatura di fusione) specific weight (and fusion temperature)</p> <table border="0"> <tr> <td>Acciaio - Steel</td> <td>7,8 - 7,9</td> <td>(1400-1515)</td> </tr> <tr> <td>Alluminio - Aluminum</td> <td>2,70</td> <td>(660)</td> </tr> <tr> <td>Ferro - Iron</td> <td>7,86</td> <td>(1539)</td> </tr> <tr> <td>Magnesio - Magnesium</td> <td>1,74</td> <td>(650)</td> </tr> <tr> <td>Ottone - Brass</td> <td>8,2 - 8,7</td> <td>(932)</td> </tr> <tr> <td>Piombo - Lead</td> <td>11,34</td> <td>(327)</td> </tr> <tr> <td>Stagno - Tin</td> <td>7,3</td> <td>(232)</td> </tr> <tr> <td>Rame - Copper</td> <td>8,95</td> <td>(1083)</td> </tr> <tr> <td>Zinco - Zinc</td> <td>7,1</td> <td>(419)</td> </tr> </table> <p>Attenzione: il peso delle leghe può differire in maniera sensibile da quello dei materiali puri. Please take note: the weight of alloys can change remarkably from the raw material one.</p>	Acciaio - Steel	7,8 - 7,9	(1400-1515)	Alluminio - Aluminum	2,70	(660)	Ferro - Iron	7,86	(1539)	Magnesio - Magnesium	1,74	(650)	Ottone - Brass	8,2 - 8,7	(932)	Piombo - Lead	11,34	(327)	Stagno - Tin	7,3	(232)	Rame - Copper	8,95	(1083)	Zinco - Zinc	7,1	(419)
Acciaio - Steel	7,8 - 7,9	(1400-1515)																										
Alluminio - Aluminum	2,70	(660)																										
Ferro - Iron	7,86	(1539)																										
Magnesio - Magnesium	1,74	(650)																										
Ottone - Brass	8,2 - 8,7	(932)																										
Piombo - Lead	11,34	(327)																										
Stagno - Tin	7,3	(232)																										
Rame - Copper	8,95	(1083)																										
Zinco - Zinc	7,1	(419)																										

SCHEDA TECNICA • SPECIFICATION LIST

tipo anodo type anode	lega in zinco zinc alloy	lega in alluminio aluminum alloy	lega in magnesio magnesium alloy
peso specifico g/cm ³ density g/cm ³	7,14	2,80	1,80
capacità di corrente AH/kg current capacity AH/kg	780	2750	1105
rendimento elettrico current efficiency	95%	95%	50%
metallo consumato per produrre 1 A/anno kg alloy consumed to produce 1 A/year kg	11,20	3,2	7,9
potenziale m V/AG/AGCL potential m V/AG/AGCL	-1100	-1150	-1550

**POTENZIALE DI PROTEZIONE DEI METALLI PIÙ UTILIZZATI
 PROTECTION POTENTIAL OF THE MOST USED METALS**

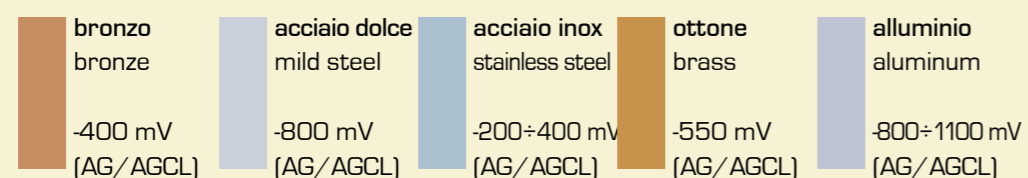

company profile	company profile	2
tabelle di conversione	conversion tables	6
indice	index	7

Scafi / Hulls

flange	flanges	8
piastre per flaps	plates for flaps	11
piastre per scafo	plates for hull	14
anodi a saldare per scafo	anodes to weld for hulls	22
ogive coniche	conic ogives	24
ogive esagonali	hexagonal ogives	27
ogive	ogives	28
anodi per assi	anodes for shafts	35
barrotti	rods	38
anodi sospesi	suspended anodes	39
barre	bars	40

Motori / Motors

volvo penta	42	dufour	106
mercury - mercruiser	53	renault - marine c.	106
bombardier - omc - johnson - evinrude	64	selva	107
bmw	72	bukh	111
gori	73	castoldi	112
j-prop	74	kamewa	113
ogive sleipner	75	hydromarine	115
mariner - yamaha	76	arneson	115
suzuki	90	hamilton	116
tohatsu	94	side power	117
yanmar	96	filtro per acqua	118
honda	100	ogive per bow thrust	118
isoterm	103	vetus	119
piaggio	103	ogive turian	122
lombardini	104	zf	122
chrysler	105		

Entrobordo / Inboard

general motors	124	mitsubishi	127
fpt-aifo	124	scania	127
caterpillar	125	baudouin	128
onan	125	lombardini	128
cummins	126	volvo penta	128
bukh	126	bmw	128
vm	126	ruggerini	128
ford	127	yamaha	128
isotta fraschini	127	castoldi	129
nanni - mercedes	127	yanmar	129
renault	127		

Accessori/Servizi tecnici	Accessories/Technical services	130
---------------------------	--------------------------------	-----

Anodi U.S.A.	U.S.A. anodes	134
--------------	---------------	-----

Flange Flanges

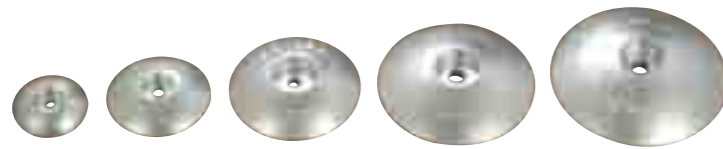

ANODI SINGOLI IN ZINCO PER TIMONI
SINGLE ANODES IN ZINC ALLOY FOR RUDDERS
serie - timoni/scafo

cod.	Ø	Ø1	Ø2	h	kg
00100	50	20	6,5	11	0,080
00101	70	22	8,5	13	0,190
00102	90	31	8,5	18	0,420

a richiesta altre misure • other measures on request

cod.	Ø	Ø1	Ø2	h	kg
00101UK	70	22	8,5	13	0,430
00102UK	100	31	8,5	18	1,000
00105UK	140	30	11	18	2,200

cod.	Ø	Ø1	Ø2	h	kg
00103	110	30	11	18	0,680
00104	125	30	11	21	0,980
00105	140	35	12	30	1,450

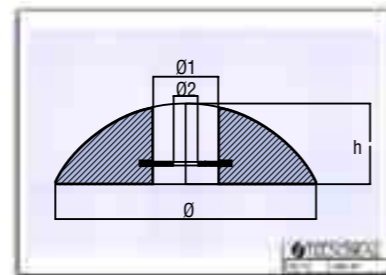

ANODI SINGOLI IN ZINCO PER TIMONI
SINGLE ANODES IN ZINC ALLOY FOR RUDDERS
serie - timoni/scafo
tipo pesante • heavy type

cod.	Ø	Ø1	Ø2	h	kg
00100P	50	21	7	15	0,130

cod.	Ø	Ø1	Ø2	h	kg
00101P	70	22	8,5	16	0,270

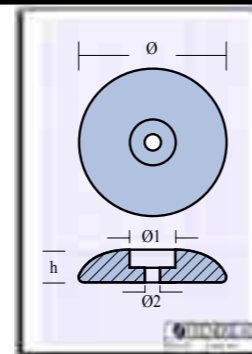

Flange Flanges

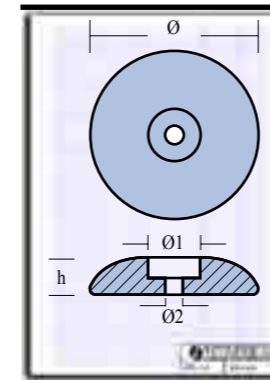

ANODI SINGOLI IN ZINCO PER TIMONI
SINGLE ANODES IN ZINC ALLOY FOR RUDDERS
serie - timoni/scafo
tipo pesante • heavy type

cod.	Ø	Ø1	Ø2	h	kg
00102P	90	27	9	20	0,510
00103P	110	30	12	21	0,860
00104P	125	30	11	26	1,270

cod.	Ø	Ø1	Ø2	h	kg
00105P	140	31	12	33	2,000
00106	190	35	13	27	3,800

articoli a richiesta • items on request

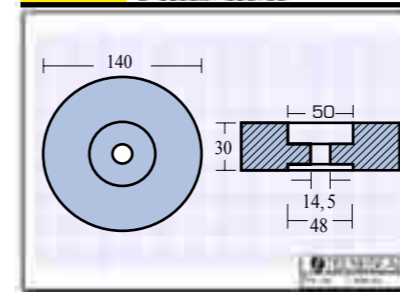

ANODI IN ZINCO PER POPPA
ANODES IN ZINC ALLOY FOR STERN
serie - poppa

cod.	Ø	h	Ø1	Ø2	kg
00130	140	30	50	14,5	2,715
SOLO ANODO - ZINC ONLY					

cod.	Ø	h	Ø1	Ø2	kg
00130C	140	30	50	14,5	3,056
COMPLETO - COMPLETE					

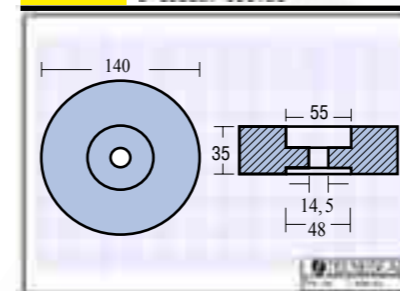

ANODI IN ZINCO PER POPPA
ANODES IN ZINC ALLOY FOR STERN
serie - poppa

cod.	Ø	h	Ø1	Ø2	kg
00131	140	35	55	14,5	3,050
SOLO ANODO - ZINC ONLY					

cod.	Ø	h	Ø1	Ø2	kg
00131C	140	35	55	14,5	3,345
COMPLETO - COMPLETE					



Flange Flanges

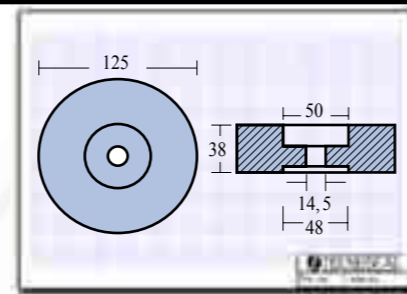

ANODI IN ZINCO PER POPPA
ANODES IN ZINC ALLOY FOR STERN
 serie - poppa

cod.	Ø	h	Ø1	Ø2	kg
00140	125	38	50	14,5	2,685
SOLO ANODO - ZINC ONLY					

cod.	Ø	h	Ø1	Ø2	kg
00141	125	38	50	14,5	3,090
COMPLETO - COMPLETE					

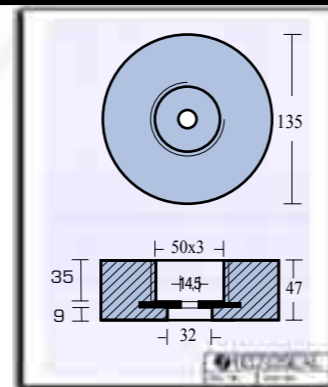

ANODI IN ZINCO PER POPPA
ANODES IN ZINC ALLOY FOR STERN
 serie - Baglietto
 tappo in PP di serie - tappo in zinco opzionale
 standard PP plug - zinc plug optional

cod.	Ø	h	Ø1	Ø2	kg
00152	135	47	50x3	32	3,900
SOLO ANODO - ZINC ONLY					

cod.	Ø	h	Ø1	Ø2	kg
00153	135	47	50x3	32	4,165
COMPLETO - COMPLETE					

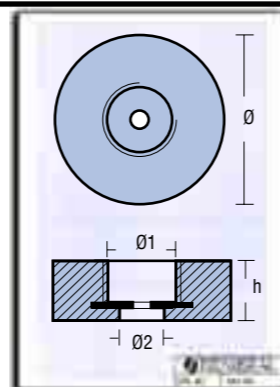

ANODI IN ZINCO PER POPPA
ANODES IN ZINC ALLOY FOR STERN
 serie - Baglietto
 tappo in PP di serie - tappo in zinco opzionale
 standard PP plug - zinc plug optional

cod.	Ø	h	Ø1	Ø2	kg
00154	120	35	50x3	32	2,050
SOLO ANODO - ZINC ONLY					

cod.	Ø	h	Ø1	Ø2	kg
00154C	120	35	50x3	32	2,318
COMPLETO - COMPLETE					

Flange Flanges

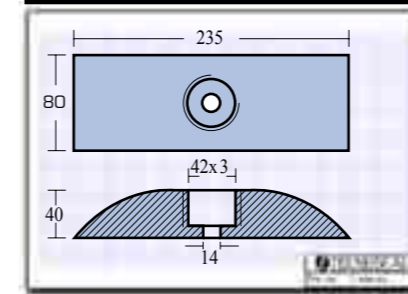

ANODI IN ZINCO PER POPPA
ANODES IN ZINC ALLOY FOR STERN
 serie - Cap

cod.	l	a	h	Ø1	Ø2	kg
00160	235	80	40	42x3	14,5	4,000

cod.	l	a	h	Ø1	Ø2	kg
00162	235	80	40	42x3	14,5	4,300
COMPLETO - COMPLETE						

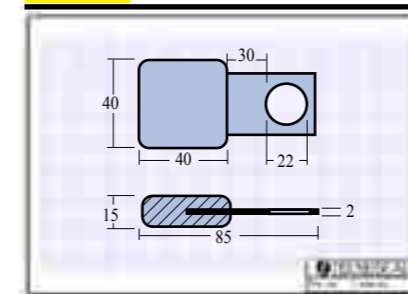

PIASTRA PER BOE DI STAZIONAMENTO CON INSERTO INOX
PLATE FOR STANDING BUOY WITH STAINLESS STEEL STRAP

cod.	kg
00170	0,170



Piastre per flaps Plates for flaps

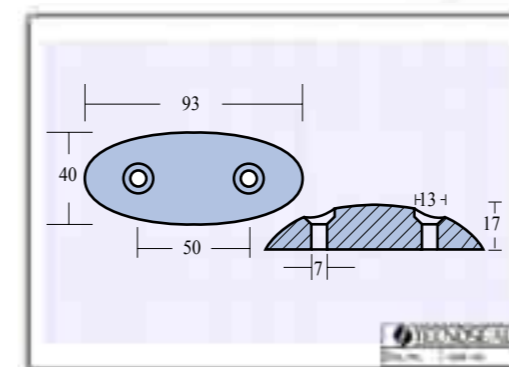

SERIE - OVALE

cod.	l	a	h	i	Ø	kg
00200	93	40	17	50	7	0,190

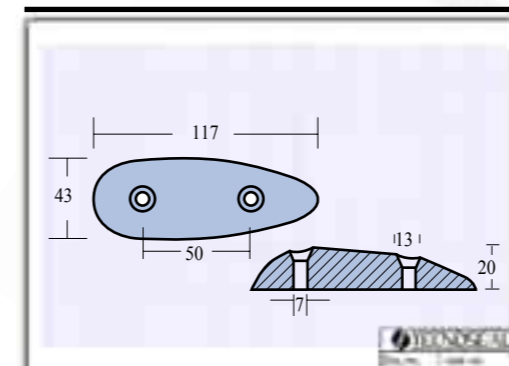

SERIE - OVALE

cod.	l	a	h	i	Ø	kg
00201	117	43	20	50	7	0,325



Piastre per flaps Plates for flaps

Piastre per flaps Plates for flaps

Scafi / Hulls

Scafi / Hulls

SERIE - DOPPIA OVALE

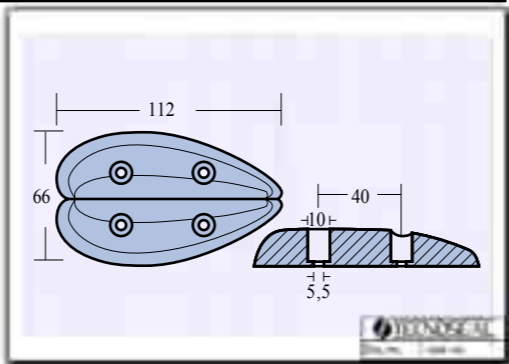

cod.	l	a	h	i	Ø	kg
00202	112	66	19	40	5,5	0,465

SERIE - OVALE

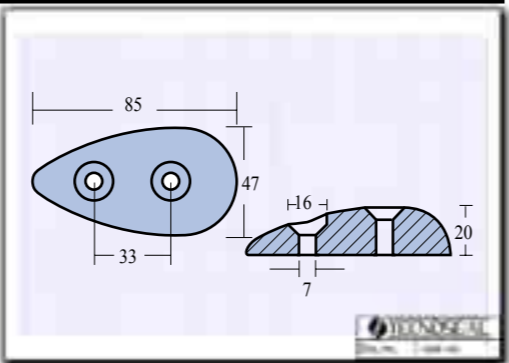

cod.	l	a	h	i	Ø	kg
00203	85	47	20	33	7	0,300

SERIE - OVALE

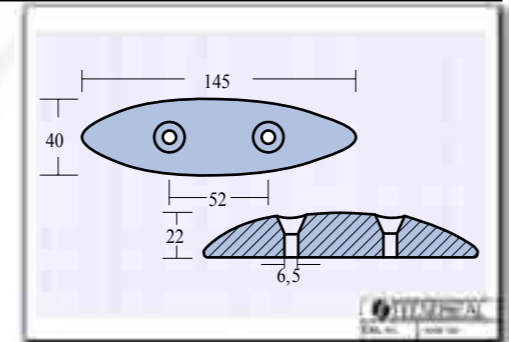

cod.	l	a	h	i	Ø	kg
00204	145	40	22	52	6,5	0,510

SERIE - ANODO OVALE PER FLAP "GALEON"

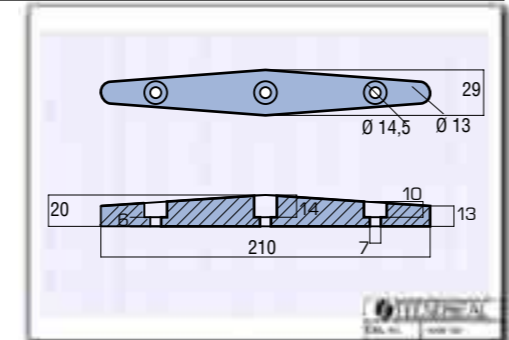

cod.	l	a	h	i	Ø	kg
00204GALE	210	29	20	52	14,5	0,500

SERIE - FLAPS SAIPEM

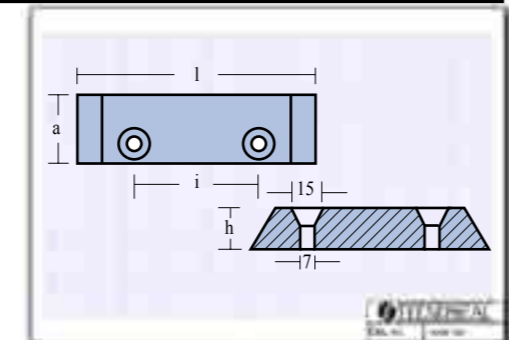

cod.	l	a	h	i	Ø	kg
00205	118	33	19	60	7	0,455

cod.	l	a	h	i	Ø	kg
00206	175	39	19	100	7	0,820

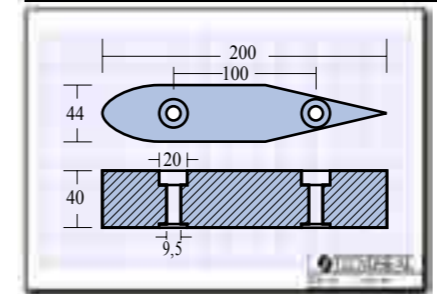

SERIE - RIVA THALASSA



cod.	l	a	h	i	Ø	kg
00207	200	44	40	100	9,5	1,735

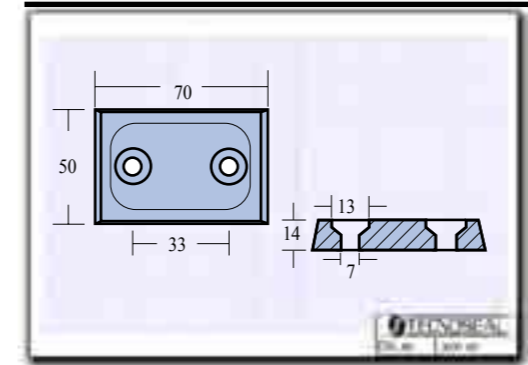

SERIE - FLAPS BOSTON WHALER



cod.	l	a	h	i	Ø	kg
00209	70	50	14	33	7	0,280

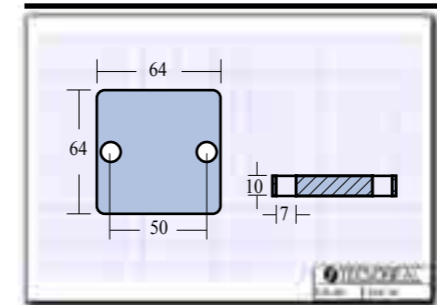

SERIE - QUADRATA

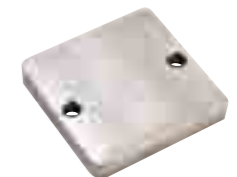

cod.	l	a	h	i	Ø	kg
00210	64	64	10	50	7	0,265

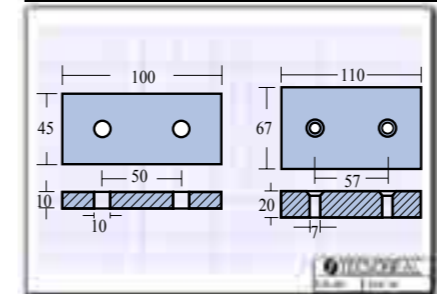

SERIE - RETTANGOLARE



cod.	l	a	h	i	Ø	kg
00211	100	45	10	50	10	0,275

cod.	l	a	h	i	Ø	kg
00212	110	67	20	57	7	0,975

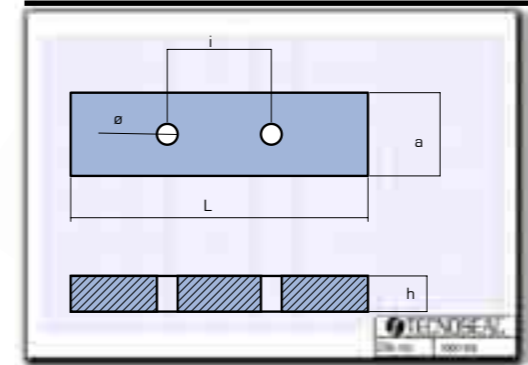

SERIE - FLAPS ACQUARIVA



cod.	L	a	h	i	Ø	kg
00212RIVA	100	28	12	35	7	0,240

Piastre per flaps Plates for flaps

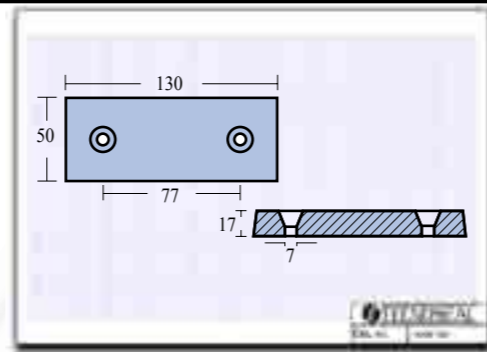
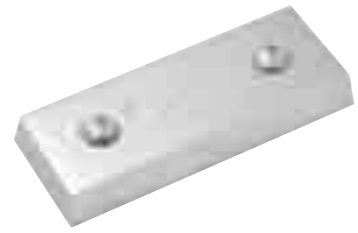

SERIE - FLAPS

cod.	l	a	h	i	Ø2	kg
00213	130	50	17	77	7	0,680

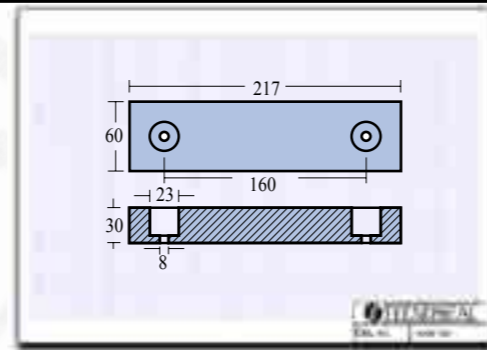

SERIE - RIVA

cod.	l	a	h	i	Ø2	kg
00214	217	60	30	160	8	2,400

Piastre per scafi Plates for hulls

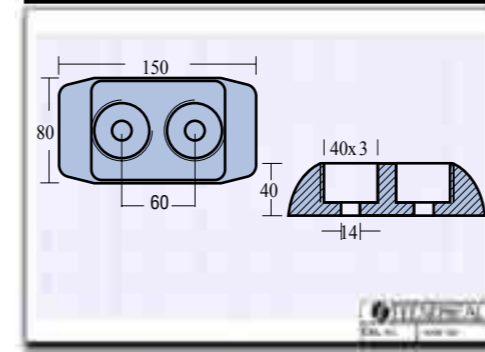

SERIE - MMI

cod.	l	a	h	i	Ø2	kg
00217	150	80	40	60	14	2,800

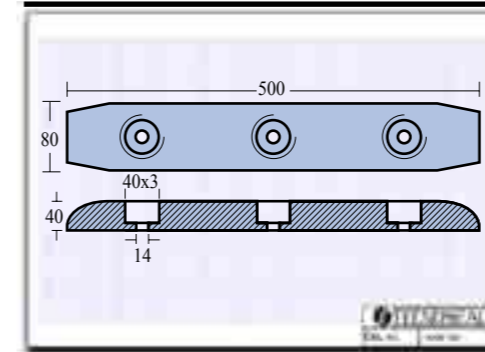

SERIE - MMI

cod.	l	a	h	i	Ø2	kg
00218	500	80	40	160	14	10,00

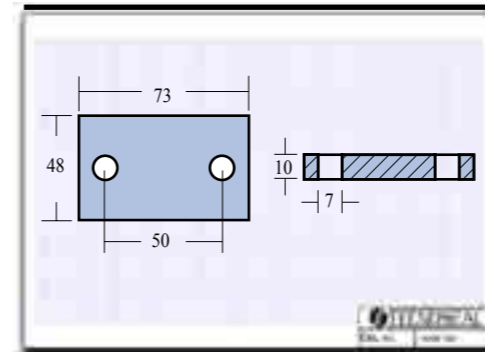

SERIE - RETTANGOLARE

cod.	l	a	h	i	Ø2	kg
00219	73	48	10	50	7	0,230

Piastre per scafi Plates for hulls

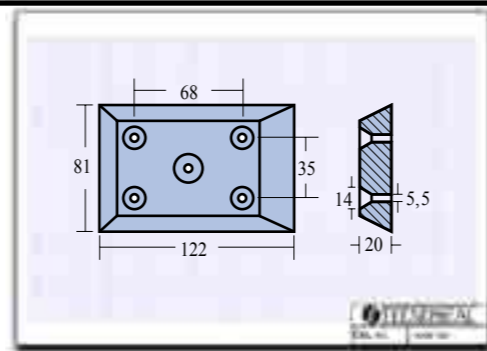

SERIE - POSILLIPO

cod.	l	a	h	fori	Ø2	kg
00215	122	81	20	5	5,5	1,055

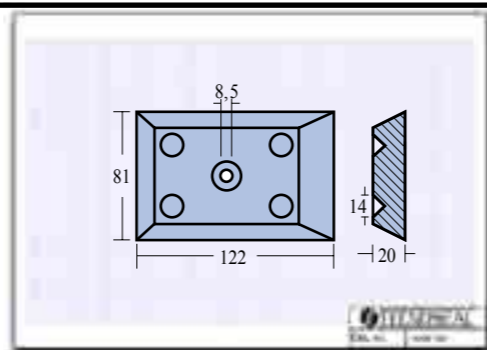

SERIE - POSILLIPO

cod.	l	a	h	fori	Ø2	kg
00216	122	81	20	5	8,5	1,070

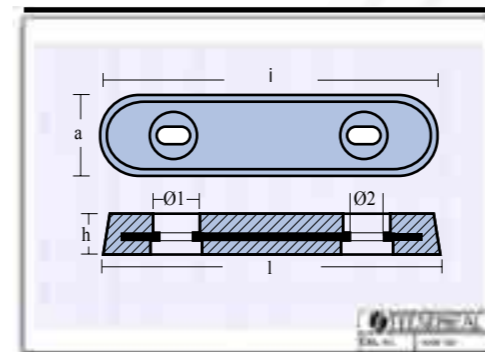

SERIE - VET

cod.	l	a	h	i	ref.vetus	Ø1	Ø2	kg
00220	150	60	25	80	15	27	11x15	1,0
00221	250	63	29	140	25	32	13x25	2,3



cod.	l	a	h	i	ref.vetus	Ø1	Ø2	kg
00222	290	55	30	200	-	32	13x25	2,7
00223	350	72	35	200	35	38	13x25	4,5

Piastre per scafi Plates for hulls

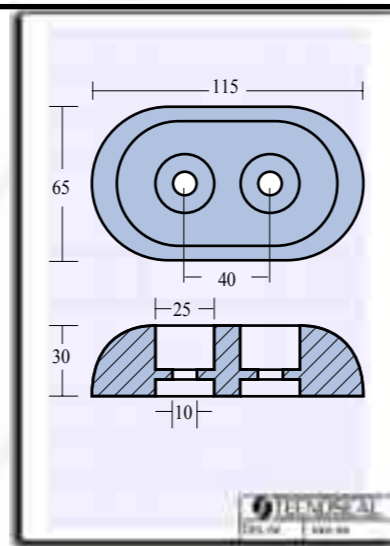

SERIE - HYDROMARINE

cod.	l	a	h	i	Ø	kg
00224	115	65	30	40	11	1,00

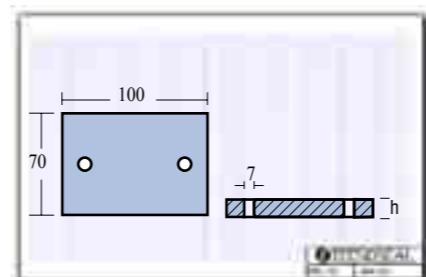
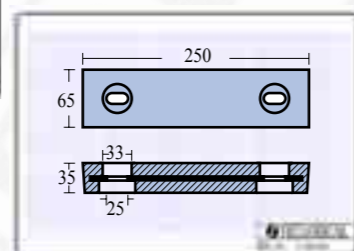
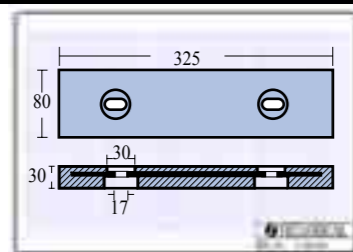

SERIE - PIASTRE SCAFO

cod.	l	a	h	i	Ø	kg
00225	325	80	30	180	13x25	4,950
00226	250	65	35	180	13x25	3,400

cod.	l	a	h	i	Ø	kg
00229	100	70	12	70	8	0,560

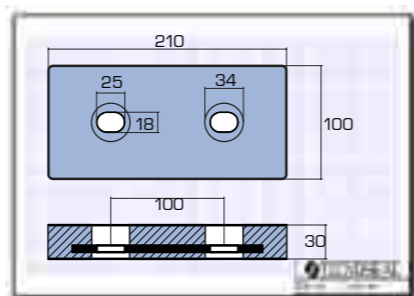
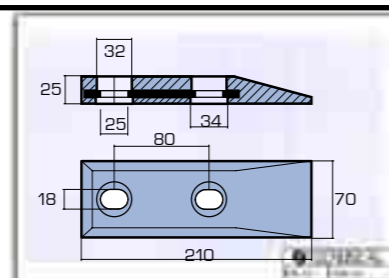

SERIE - SCAFI VELOCI

cod.	l	a	h	i	Ø	kg
00230	210	70	25	80	18x25	1,850

cod.	l	a	h	i	Ø	kg
00231	210	100	30	100	18x25	3,780

Piastre per scafi Plates for hulls

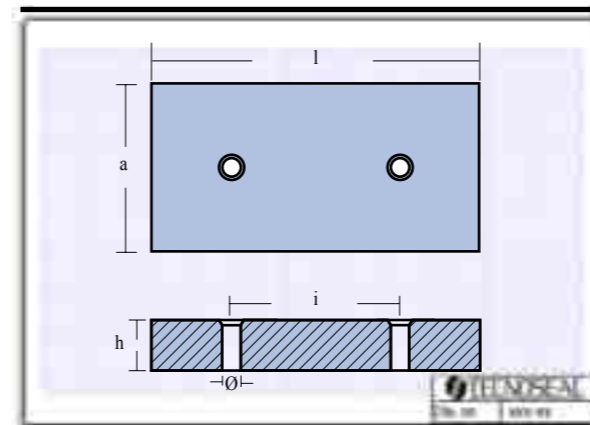

SERIE - RETTANGOLARE



cod.	l	a	h	i	Ø	kg
00233	400	80	30	250	10,5	7,000
00237	220	100	30	120	10,5	4,300

cod.	l	a	h	i	Ø	kg
00240	490	48	20	s.f.		3,020
00241	200	100	23	100	10,5	3,200

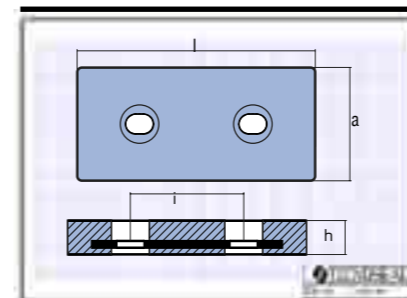

SERIE - RETTANGOLARE



cod.	l	a	h	i	Ø	kg
00234	180	65	30	104	13x25	2,000
00235	190	65	30	102	13x15	2,300
00236	200	80	22	110	13x25	2,500

cod.	l	a	h	i	Ø	kg
00238	210	100	30	110	19x25	4,180
00242	280	85	30	160	13x25	4,200
00243	147	65	22	70	13x25	1,200

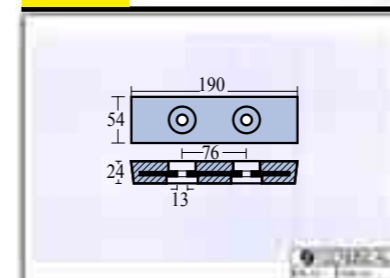

SERIE - GDF

cod.	l	a	h	i	Ø	kg
00239	190	54	24	76	13	1,450

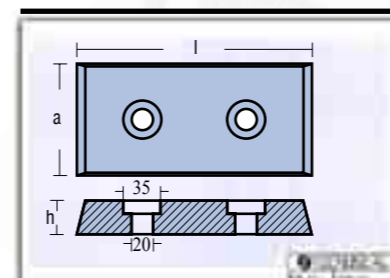

cod.	l	a	h	i	Ø	kg
00244	290	90	32	160	20	5,000

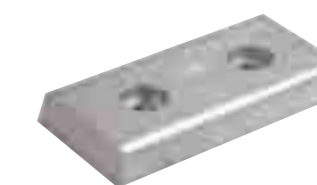

Piastre per scafi Plates for hulls

Piastre per scafi Plates for hulls

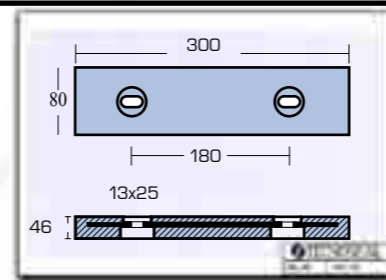

cod.	l	a	h	i	Ø	kg
00245	300	80	46	180	13x25	7,000

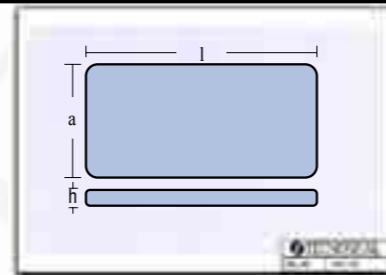

SERIE - CALDAIA

cod.	l	a	h	kg
00250	300	150	10	3,25

cod.	l	a	h	i	kg
00254	300	200	20		8,5

00251	300	150	16,5	4,8
--------------	-----	-----	------	-----

00255	300	150	26	125	8,0
--------------	-----	-----	----	-----	-----

00252	300	150	22	6,4
--------------	-----	-----	----	-----

00256	300	150	33	9,8
--------------	-----	-----	----	-----

00253	300	150	27	8,0
--------------	-----	-----	----	-----

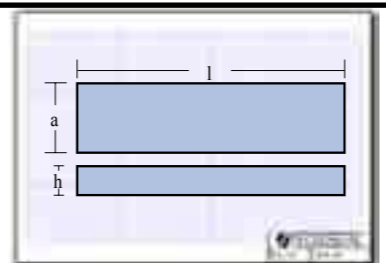

SERIE - PF2

cod.	l	a	h	kg
00260	190	50	25	1,520

SERIE - FLAPS

cod.	l	a	h	kg
00262	200	100	20	2,600

SERIE - PF3

00261	190	65	30	2,400
--------------	-----	----	----	-------

00263	130	80	30	2,000
--------------	-----	----	----	-------

00264	300	150	28	160	40	16x25	8,000
--------------	-----	-----	----	-----	----	-------	-------

00265	200	70	30	110	35	13x25	2,700
--------------	-----	----	----	-----	----	-------	-------

SERIE - FLAPS

cod.	l	a	h	i	Ø	Ø2	kg
00264	300	150	28	160	40	16x25	8,000

00265	200	70	30	110	35	13x25	2,700
--------------	-----	----	----	-----	----	-------	-------

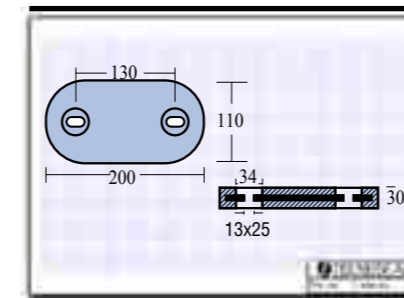
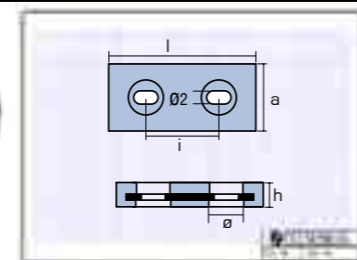

SERIE - SEA RAY

cod.	l	a	h	i	Ø	kg
00266	200	110	30	130	13x25	3,900

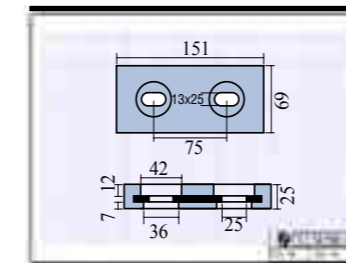

**PIASTRA PER SCAFO CON ASOLE
HULL BOLT-ON PLATE**

cod.	l	a	h	i	Ø	kg
00267	151	69	25	75	13x25	1,520

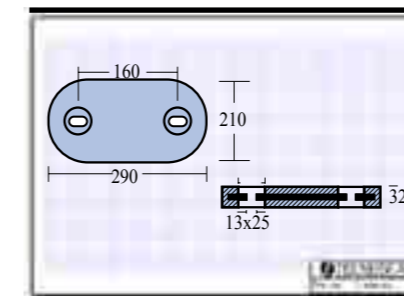

PIASTRA OVALE

cod.	l	a	h	i	Ø	kg
00266E	290	210	32	160	13x25	9,800

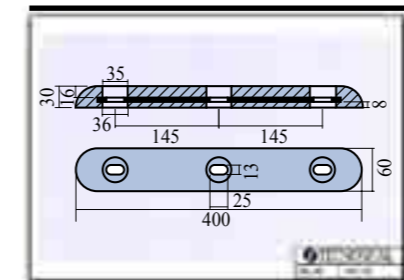

**ANODO 3 FORI L400
3 HOLES ANODE**

cod.	l	a	h	i	Ø	kg
00268E	400	60	30	145	13x25	3,500

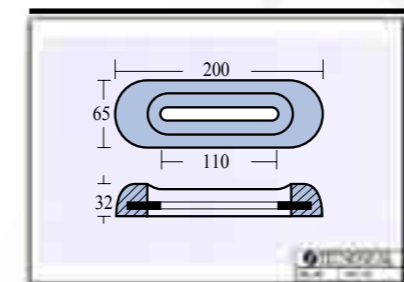

SERIE FAIRLINE

cod.	l	a	h	i	Ø	kg
00269E	200	65	32	110	12	1,300



Piastre per scafi Plates for hulls

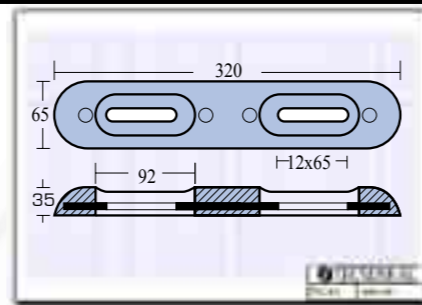
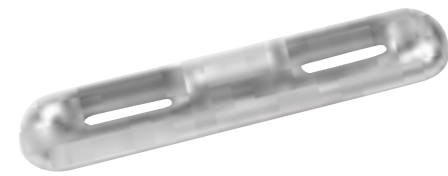

SERIE - FAIRLINE

cod. l a h i kg

00270E  320 65 35 160 2,20

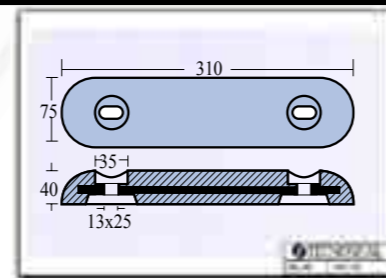
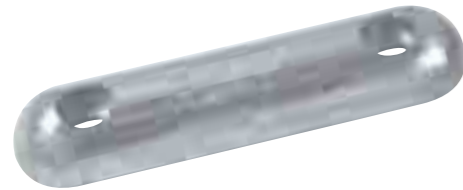

SERIE - FAIRLINE

cod. l a h i kg

00271E  310 75 40 205 4,000

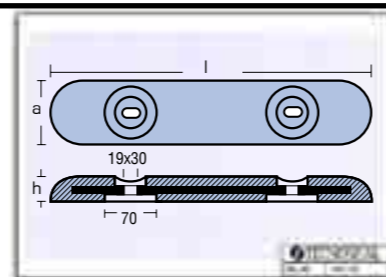

SERIE - FAIRLINE

cod. l a h i kg

00272E  455 90 40 230 7,000

cod. l a h i kg

00273E  460 100 45 230 10,800

Piastre per scafi Plates for hulls

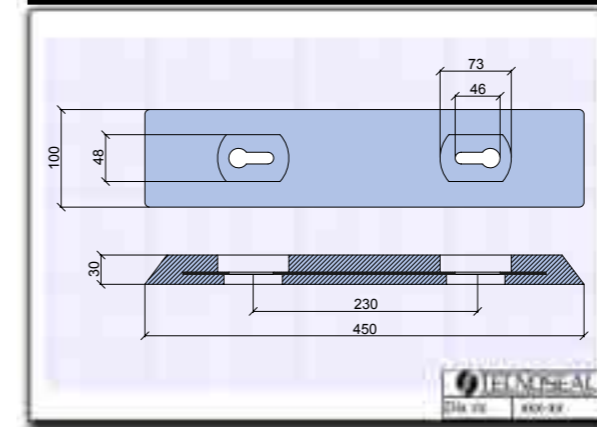

PIASTRA SEALINE CON INSERTO IN ACCIAIO
SEALINE PLATE WITH STAINLESS STEEL STRAP

cod. l a h i kg

00274E  450 100 30 230 7,200

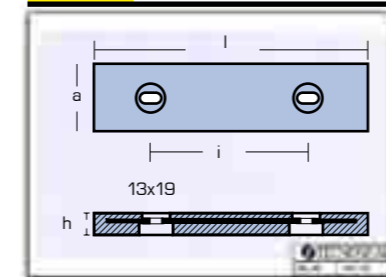

PIASTRA CON INSERTO IN ACCIAIO
PLATE WITH STAINLESS STEEL STRAP

cod. l a h i kg

00275E  455 105 35 230 9,000

PIASTRA CON INSERTO IN ACCIAIO
PLATE WITH STAINLESS STEEL STRAP

cod. l a h i kg

00276E  455 100 40 230 12,000

PIASTRA CON INSERTO IN ACCIAIO
PLATE WITH STAINLESS STEEL STRAP

cod. l a h i kg

00277E  455 100 47 230 14,000

PIASTRA CON INSERTO IN ACCIAIO
PLATE WITH STAINLESS STEEL STRAP

cod. l a h i kg

00278E  600 125 65 300 28,000



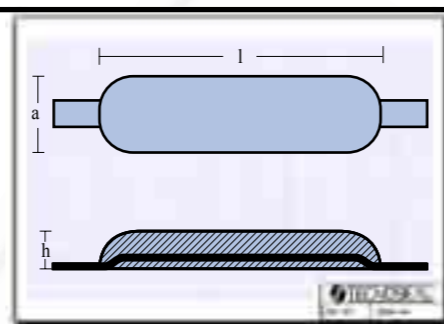
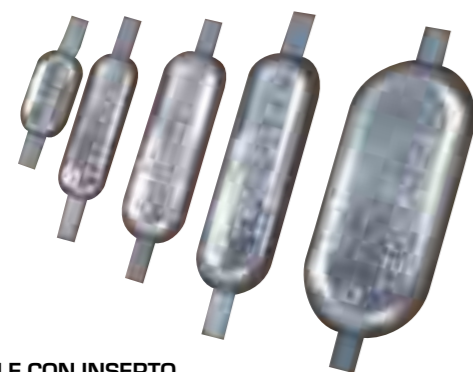

SERIE - OVALE CON INSERTO

SERIE - SETTORE NAVALE

cod.	l	a	h	OV	inserto-strap	kg
00300	115	60	17	0,5	200 x 25 x 5	0,6
00301	110	63	26	1	200 x 25 x 5	1,0
00302	200	70	25	1,8	300 x 25 x 5	1,8
00303	215	70	29	2,2	300 x 25 x 5	2,2
00304	200	90	35	3	300 x 25 x 5	3,0

cod.	l	a	h	OV	inserto-strap	kg
00305	250	90	36	4	340 x 25 x 5	4,0
00306	300	80	40	5	400 x 30 x 6	5,0
00307	295	90	40	6	400 x 30 x 6	5,6
00308	300	125	40	8	400 x 30 x 6	7,8
00309	320	147	40	10	400 x 30 x 6	10,0
00310	400	152	33	12	550 x 40 x 6	12,20

disponibili anche in alluminio
available in aluminum, too

per misure più grandi vedere catalogo navale
bigger sizes in commercial catalogue

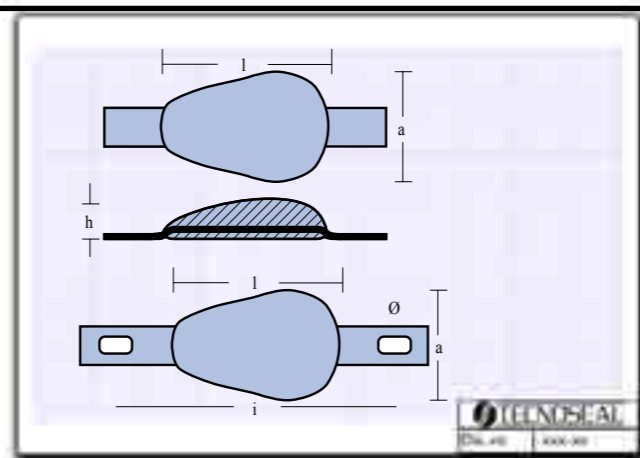

SERIE - GOCCIA CON INSERTO

SERIE - GOCCIA CON INSERTO ASOLATO

cod.	l	a	h	inserto-strap	kg
00350	120	78	25	230 x 25 x 5	1,0
00351	140	90	35	250 x 25 x 5	1,8
00352	165	100	42	250 x 25 x 5	3,0

cod.	l	a	h	inserto-strap	Ø	i	kg
00350B	120	78	25	265 x 25 x 5	13x25	200	1,0
00352/A	165	100	42	265 x 25 x 5	13x25	200	3,0

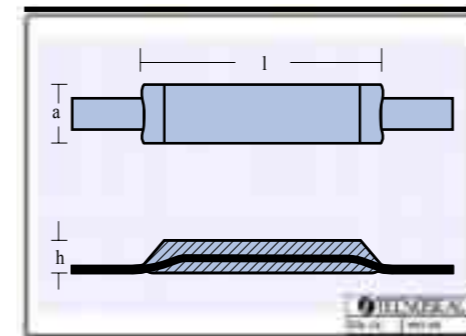

SERIE - LINGOTTO CON INSERTO

cod.	l	a	h	inserto-strap	kg
00380	190	50	26	300 x 25 x 5	1,6

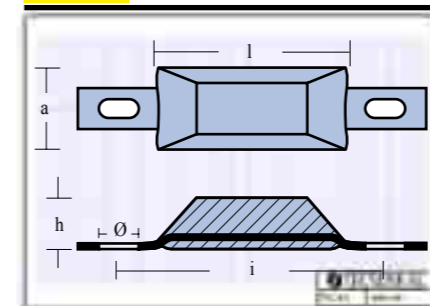

SERIE - LINGOTTO CON INSERTO ASOLATO

cod.	l	a	h	inserto	Ø	i	kg
00385	75	34	16	175x20x3	9x20	133	0,250
00385/1	95	34	17	165x15x3	7x25	117	0,260
00386	95	40	25	170x15x3	9x20	129	0,500



cod.	l	a	h	inserto-strap	kg
00381	200	60	32	300 x 25 x 5	2,4

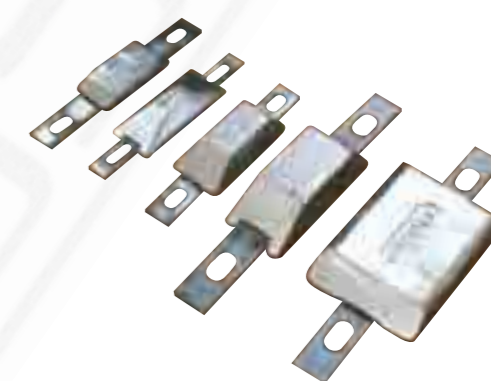

cod.	l	a	h	inserto	Ø	i	kg
00387	120	46	35	250x25x5	13x25	180	1,100
00387/1	127	66	25	250x25x5	13x25	180	1,040
00388	140	82	26	250x25x5	13x25	180	1,900

Ogive coniche Conic ogives



SERIE - TIPO RADICE RICAMBIO IN ZINCO CONICO
ZINC ONLY

cod.	Ø asse	Ø	Ø1	Ø2	Ø3	h	kg
00400	22-25	33	25,0	6,5	11,0	39	0,135
00401	30	42	32,0	8,5	13,5	53	0,280
00402	35	46	38,0	8,5	13,5	61	0,390
00403	40	51	42,0	8,5	14,0	68	0,505
00404	45	61	48,0	11,0	24,0	76	0,845

cod.	Ø asse	Ø	Ø1	Ø2	Ø3	h	kg
00405	50	73	57,0	11,0	27,0	84	1,180
00406	55	75	65,0	11,0	28,0	87	1,135
00407	60	82	71,0	11,0	24,0	98	1,845
00409	100	98	84,5	11,0	17,0	98	2,260
00409/1	110	160	130,0	15,0	24,0	134	7,650



SERIE - TIPO RADICE ANODO COMPLETO
DI OTTONE CONICO STANDARD
COMPLETE WITH BRASS

cod.	Ø asse	Ø	Ø1	h	h1	c	kg
00410	22-25	37	16 x 1,5	20	18	30	0,305
00411	30	45	20 x 1,5	22	21	32	0,535
00412	35	50	24 x 2,0	24	24	36	0,745

cod.	Ø asse	Ø	Ø1	h	h1	c	kg
00413	40	55	24 x 2,0	27	27	41	1,065
00414	45	65	33 x 2,0	30	30	50	1,590
00415	50	75	36 x 3,0	29	33	54	2,220

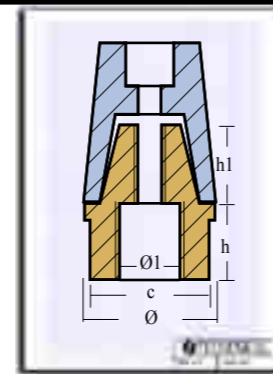
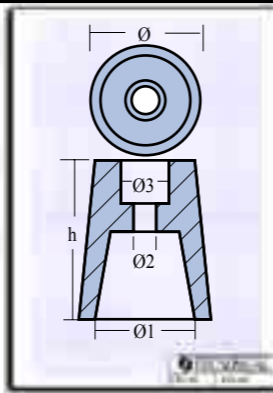

Ogive coniche Conic ogives

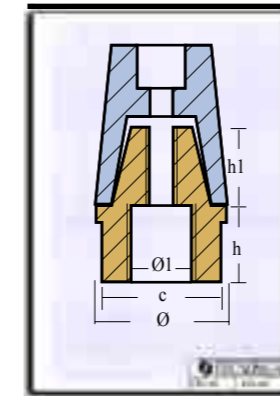

SERIE - TIPO RADICE ANODO COMPLETO
DI OTTONE CONICO STANDARD
COMPLETE WITH BRASS

cod.	Ø asse	Ø	Ø1	h	h1	c	kg
00416	55	80	40 x 3,0	40	40	63	2,795
00417	60	90	45 x 3,0	41	44	63	3,825

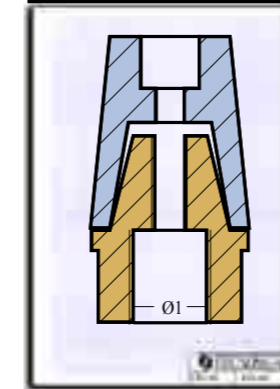

SERIE - TIPO RADICE ANODO COMPLETO
DI OTTONE CONICO FUORI STANDARD
COMPLETE WITH BRASS

cod.	Ø1	kg
00410/1	14 x 1,5	0,305
00410/2	18 x 1,5	0,290
00410/3	20 x 1,5	0,270
00410/4	16 x 2,0	0,300
00410XC	con foro Ø 8	0,350
00411/1	14 x 1,5	0,590
00411/2	22 x 1,5	0,525
00411XC	con foro Ø 10	0,600

cod.	Ø asse	Ø	Ø1	h	h1	c	kg
00419	100	100	50 x 3,0	46	54	75	5,880



cod.	Ø1	kg
00412/1	22 x 1,5	0,780
00412/2	14 x 1,5	0,840
00412/3	24 x 1,5	0,750
00413/1	26 x 2,0	1,095
00413/2	14 x 1,5	1,190
00413/3	24 x 1,5	1,070
00414/1	27 x 1,5	1,650
00414/2	30 x 2,0	1,615

Ogive coniche Conic ogives

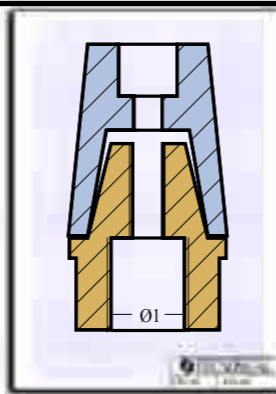

SERIE - TIPO RADICE ANODO COMPLETO DI OTTONE CONICO FUORI STANDARD COMPLETE WITH BRASS

cod.	Ø1	kg
00414/3	27 x 2,0	1,655
00414/4	16 x 1,5	1,785
00414/5	26 x 1,5	1,860
00414/6	36 x 3,0	1,520
00415/1XC	con foro Ø12	2,655
00415/2	27 x 1,5	2,370

cod.	Ø1	kg
00416/1XC	con foro Ø12	3,400
00417/2	34 x 2,0	4,185
00419/1	38 x 2,5	6,620
00419/2XC	con foro Ø12	7,145
00419/3	45 x 2,5	6,375
00419/4	54 x 2,5	6,125

A richiesta disponibile ogiva tipo radice, completa di ottone con preforo per assi elica diametro fuori standard in tutte le misure (aggiungere al codice **XC**)
Available on request ogive of any size with guide only Ø 12 on the brass (add **XC** to the code)

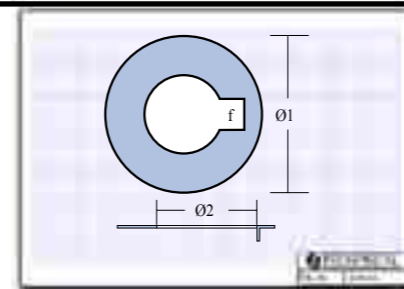

SERIE - TIPO RADICE RONDELLA INOX

cod.	Ø1	Ø2	f	kg
00410 R per 00410	38	16,5	6	0,005
00411 R per 00411	46	20,5	8	0,010
00412 R per 00412	51	24,0	10	0,010
00413 R per 00413	53	24,0	12	0,015
00414 R per 00414	66	33	12	0,020

cod.	Ø1	Ø2	f	kg
00415 R per 00415	76	37	14	0,025
00416 R per 00416	81	40	16	0,030
00417 R per 00417	90	45	18	0,035
00419 R per 00419	100	50	20	0,050

Ogive esagonali Hexagonal ogives

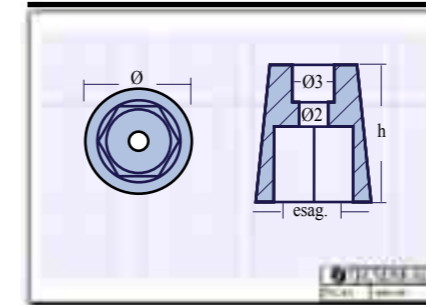

SERIE - TIPO RADICE RICAMBIO IN ZINCO ESAGONALE ZINC ONLY

cod.	Ø asse	Ø	Ø2	Ø3	esag.	h	kg
00400E	20-25	34	7	11	22	39	0,120
00401E	30	43	9	17	27	53	0,255
00402E	35	46	9	18	32	62	0,360
00403E	40	52	9	18	36	67	0,460
00404E	45	61	11	24	41	76	0,775

cod.	Ø asse	Ø	Ø2	Ø3	esag.	h	kg
00405E	50	73	11	24	46	84	0,990
00406E	55	75	11	22	50	87	1,010
00407E	60	82	11	23	45	98	1,600
00409E	100	98	11	22	54	97	2,580

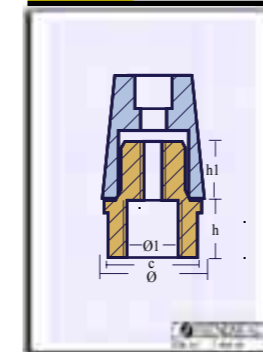

SERIE - TIPO RADICE COMPLETO IN OTTONE ESAGONALE COMPLETE WITH BRASS

cod.	Ø asse	Ø	Ø1	h	h1	c	kg
00410E	22-25	37	16 x 1,5	18	18	22	0,310
00411E	30	45	20 x 1,5	22	21	32	0,560
00412E	35	50	24 x 2,0	24	24	36	0,745
00413E	40	55	24 x 2,0	27	26	41	1,020



cod.	Ø asse	Ø	Ø1	h	h1	c	kg
00414E	45	65	33 x 2,0	29	29	50	1,530
00415E	50	75	36 x 3,0	29	44	55	2,380
00416E	55	80	40 x 3,0	35	40	60	2,525
00417E	60	90	45 x 3,0	41	44	65	3,600
00419E	100	100	50x3	46	54	75	5,640

Ogive esagonali Hexagonal ogives

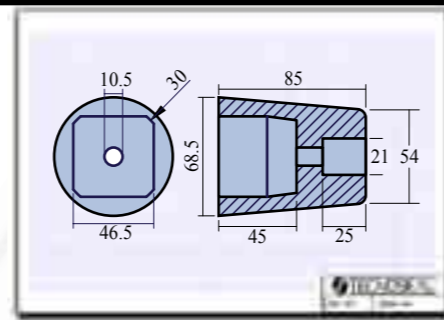

OGIVA CONICA CON INTERNO QUADRATO
ZINC ONLY

cod.	kg
00405Q	0,990

OGIVA CONICA COMPLETA DI OTTONE
COMPLETE WITH BRASS

cod.	kg	fil.
00415Q	2,240	M36x3

Ogive Ogives

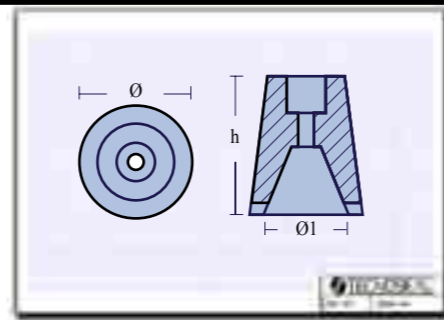

SERIE - TIPO SOLÈ

cod.	Ø	Ø1	h	kg
00400SOLE/1	32	24	39	0,120
00400SOLE/2	37	26	46	0,205

cod.	Ø	Ø1	h	kg
00400SOLE/3	47	36	60	0,335
00400SOLE/4	55	45	70	0,560

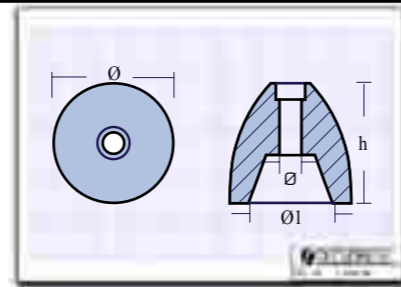

SERIE - TIPO RIVA RICAMBIO IN ZINCO

cod.	Øasse	Ø	Ø1	h	kg
00430	20-30	38	25	38	0,175
00431	35-50	52	36	50	0,330

cod.	Øasse	Ø	Ø1	h	kg
00432	50-100				0,650
	<i>a richiesta - on request</i>				
00433	40	48	35	51	0,460
	acquariva				

Ogive Ogives

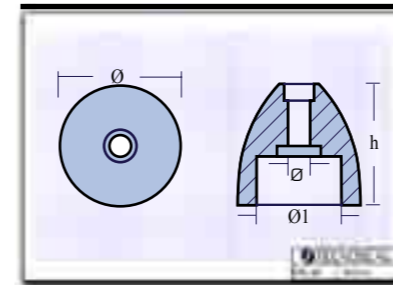

SERIE - TIPO MTF RICAMBIO IN ZINCO

cod.	Øasse	Ø	Ø1	h	kg
00430MTF	20-30	38	29	38	0,135
00431MTF	35-50	52	40	50	0,250

cod.	Øasse	Ø	Ø1	h	kg
00432MTF	50-100	66	46	73	0,76

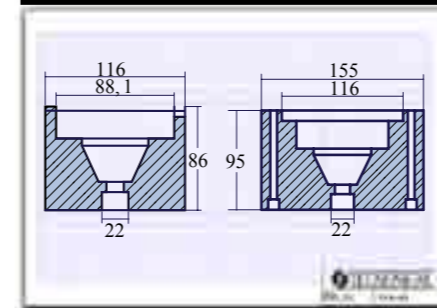

SERIE - TIPO RIVA MERCURIUS
SERIE - TIPO RIVA MERCURIUS II

cod.	Ø	Ø1	h	kg
00435	116	88,1	86	4,860

cod.	Ø	Ø1	h	kg
00436	155	116	95	10,400

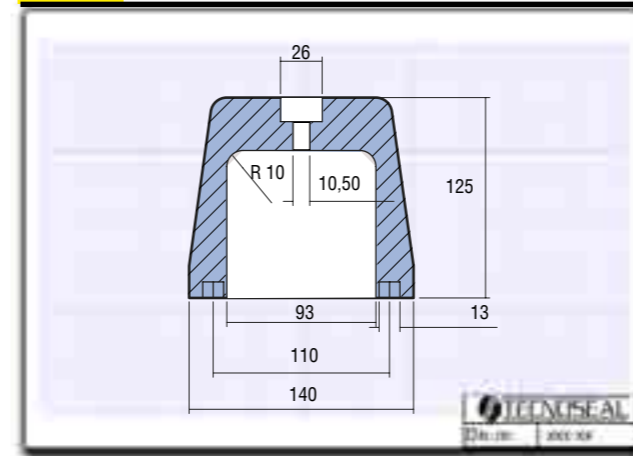

SERIE - TIPO RIVA SPLENDIDA

cod.	Ø	kg
00437	140	7,050

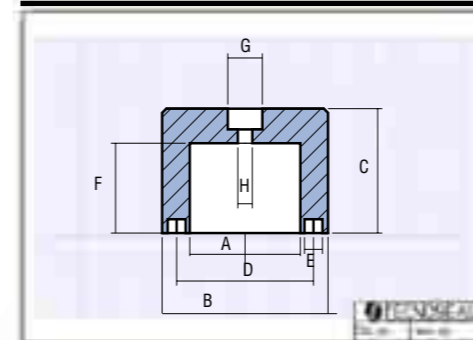

SERIE - TIPO RIVA OPERA

cod.	A	B	C	D	E	F	G	H	Kg
00438	80	120	90	99	13	65	25	10,5	4,800

SERIE - TIPO RIVA DOLCE VITA

cod.	A	B	C	D	E	F	G	H	kg
00439	92	170	100	110	13	65	28	12	12,800

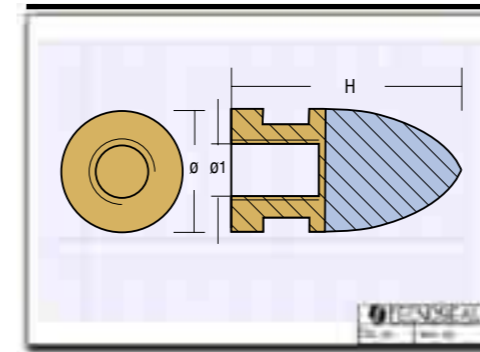
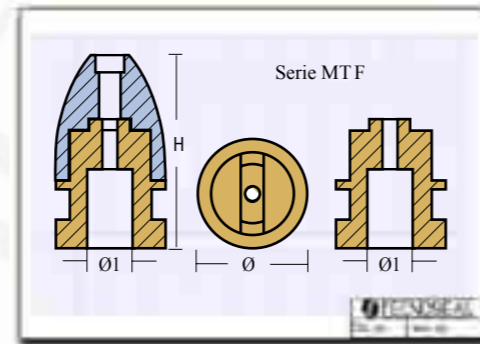
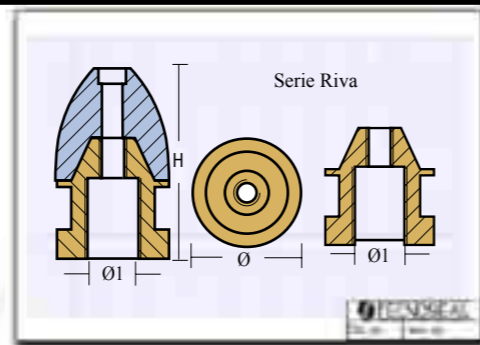

SERIE - TIPO RIVA
ANODO COMPLETO DI OTTONE Ø 38 H 60

cod.	Ø asse	Ø1	kg
00440X/C	20/30	foro non filettato	0,360
00440	20/30	14 x 1,50	0,400
00441	20/30	16 x 1,50	0,360
00442	20/30	18 x 1,50	0,380
00443 acquarama	20/30	18 x 1,75	0,380
00444	20/30	18 x 2,00	0,380
00445	20/30	3/4"W	0,380
00446	20/30	20 x 1,50	0,350
00447	20/30	20 x 2,00	0,370
00448	20/30	20 x 2,50	0,360

SERIE - TIPO RIVA
ANODO COMPLETO DI OTTONE Ø 52 H 84

cod.	Ø asse	Ø1	kg
00449X/C	35/50	foro non filettato	0,830
00449	35/50	24 x 1,50	0,960
00450 bravo	35/50	24 x 2,00	0,850
00451	35/50	26 x 2,00	0,950
00452	35/50	30 x 2,00	0,700
00453	35/50	33 x 2,00	0,960
00454	35/50	1"gas	0,700

SERIE - OGIVE FISSE Ø38 H69

cod.	Øasse	Ø	Ø1	H	kg
00440F	20-30	38	14 x 1,50	69	0,390
00441F	20-30	38	16 x 1,50	69	0,390
00442F	20-30	38	18 x 1,50	69	0,390
00443F	20-30	38	18 x 1,75	69	0,390
00444F	20-30	38	18 x 2,00	69	0,390
00445F	20-30	38	3/4"W	69	0,390
00446F	20-30	38	20 x 1,50	69	0,390
00447F	20-30	38	20 x 2,00	69	0,390
00448F	20-30	38	20 x 2,50	69	0,390

SERIE - OGIVE FISSE Ø52 H102

cod.	Øasse	Ø	Ø1	H	kg
00449F	35-50	52	24 x 1,50	102	1,090
00450F	35-50	52	24 x 2,00	102	1,090
00451F	35-50	52	26 x 2,00	102	1,090
00452F	35-50	52	30 x 2,00	102	1,090
00453F	35-50	52	33 x 2,00	102	1,090
00454F	35-50	52	1"gas	102	1,090

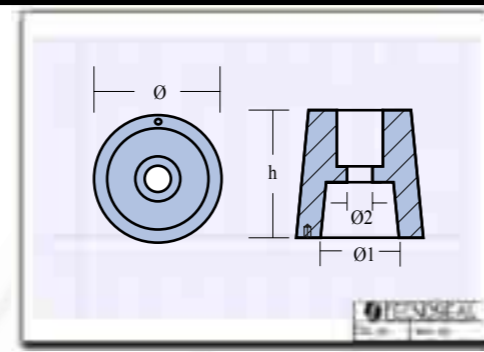

SERIE - TIPO REGGIANI NAUTICA
RICAMBIO IN ZINCO INT. CILINDRICO
ZINC ONLY

cod.	Ø asse	Ø	Ø1	Ø2	h	kg
00460	25	34	20	6,5	34	0,130
00461	30	44	25	6,5	50	0,340
00462	35	48	28	8,5	55	0,455
00463	40	54	34	11,0	55	0,535

cod.	Ø asse	Ø	Ø1	Ø2	h	kg
00464	45	64	40	11,0	65	0,950
00465	50	74	45	11,0	75	1,540
00466	55	78	48	11,0	75	1,630
00467	60	88	55	11,0	85	2,400

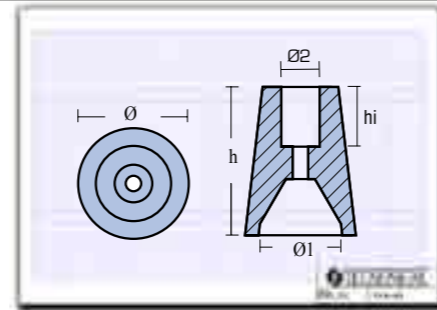

SERIE - TIPO FERRETTI
RICAMBIO IN ZINCO
ZINC ONLY

cod.	Ø asse	Ø	Ø1	Ø2	h	h1	kg
00475	40	51	35	16	67	26	0,60
00476	45	61	41	24	75	26	0,95

cod.	Ø asse	Ø	Ø1	Ø2	h	h1	kg
00477	50	54	45	15	73	30	0,63
00478 RIVARAMA	55	59	40	18	88	26	1,10

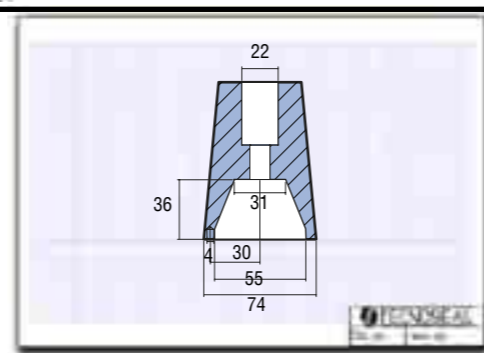

SERIE TIPO FERRETTI

cod.	Ø	Ø1	h	kg
00478/1	74	55	95	1,90

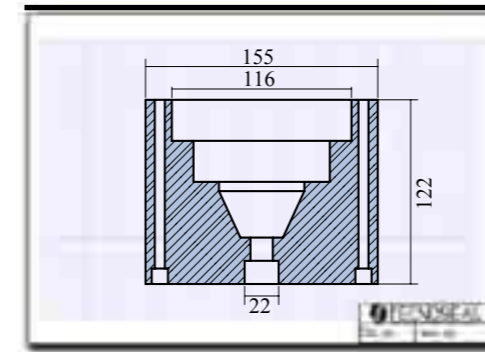

SERIE - TIPO FERRETTI 680
NUT ANODE TYPE FERRETTI 680

cod.	Ø	Ø1	h	kg
00479	155	116	122	12,524

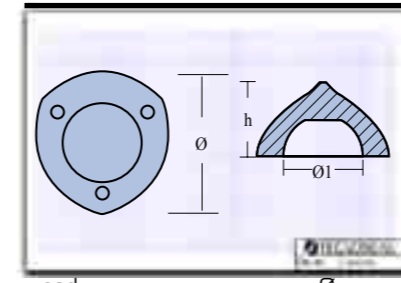
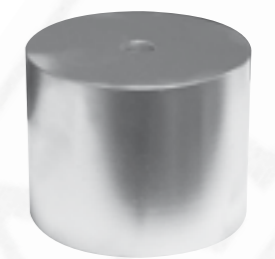

SERIE - TIPO MAX PROP
RICAMBIO IN ZINCO

cod.	Ø	Ø1	h	kg
00480	65	38	42	0,280
00481	72	42	43	0,380
00482	84	46	60	0,800



cod.	Ø	Ø1	h	kg
00483	100	52	61	1,075
00486	120	81	78	1,685

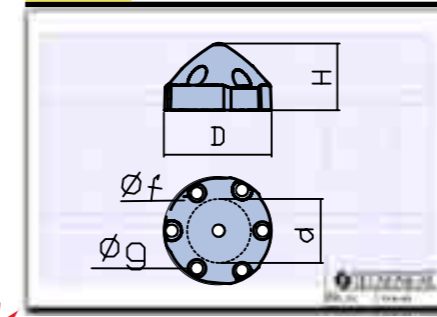

OGIVA MAX PROP 6 FORI
MAX PROP 6 HOLES OGIVE

cod.	D	d	H	f	g	kg
NEW! 00480/6	61	39	38	6,5	6,5	0,260
NEW! 00481/6	68	44	43	6,5	5	0,408

cod.	D	d	H	f	g	kg
NEW! 00482/6	80	47	55	8	6,5	0,816

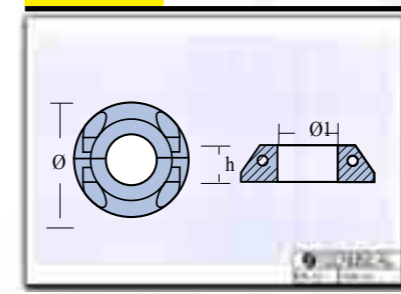

COLLARE MAX PROP

cod.	Ø	Ø1	h	kg
00484	92	42	25	0,595



cod.	Ø	Ø1	h	kg
00485	92	46	25	0,580

Ogive Ogives

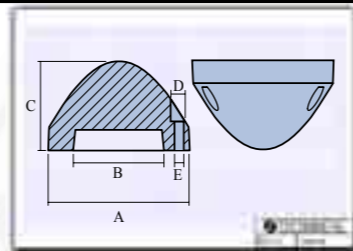
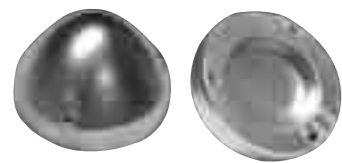

SERIE - TIPO MAX PROP A 3 PASSO VARIABILE

cod.	A	B	C	D	E	kg	cod.	A	B	C	D	E	kg
00487	60	39	38	7,5	4,46	0,300	00488	67,7	43,56	42,81	6,88	4,46	0,555



SERIE TIPO MAX PROP

cod.	Ø	kg
00489	36	0,210

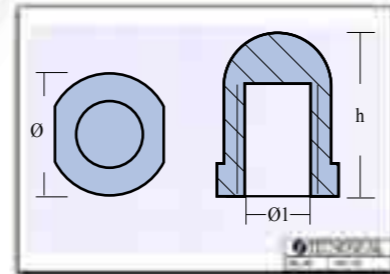
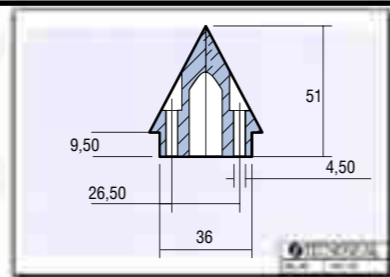

SERIE - DADI PER ASSI

cod.	Ø	Ø1	h	kg	cod.	Ø	Ø1	h	kg
00490	35	M20	52	0,155	00493	40	M30	50	0,215
00491	40	M24	50	0,250	00494	35	20x2	52	0,155
00492	40	M27	50	0,230	00495	40	26x2	50	0,240

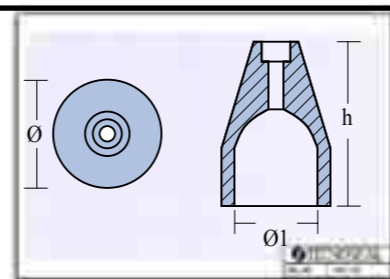
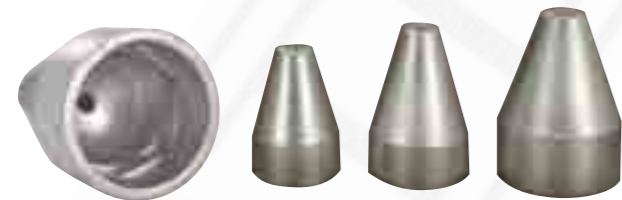

SERIE - OGIVE ORVEA

cod.	Ø	Ø1	h	kg	cod.	Ø	Ø1	h	kg
00497	56	42	85	0,635	00499	81	60	110	1,585
00498	65	55	101	0,815					

Anodi per assi Anodes for shafts

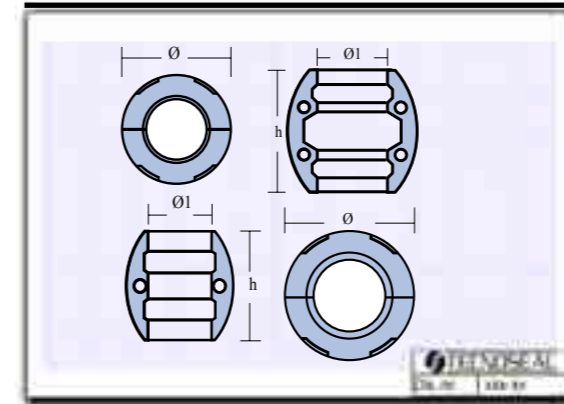

BRACCIALI PER ASSI • SHAFTS ANODES

SERIE - Ø 19-100 ASSE STANDARD - STANDARD SHAFTS
Ø 100-160 A RICHIESTA - ON REQUEST

cod.	Ø asse	Ø	Ø1	h	fori	kg	cod.	Ø asse	Ø	Ø1	h	fori	kg
00500	19,0	58	19,0	56	2	0,525	00510	38,0	65	38,0	66	4	0,520
00501	22,0	58	22,0	56	2	0,500	00511	40,0	81	40,0	77	4	0,965
00502	25,0	58	25,0	56	2	0,480	00511M	44,4	81	44,4	77	4	0,880
00503	25,4	58	25,4	56	2	0,485	00512	45,0	81	45,0	77	4	0,850
00504	28,0	58	28,0	56	2	0,450	00513	50,0	93	50,0	88	4	1,180
00505	28,6	58	28,6	56	2	0,445	00514	50,8	93	50,8	88	4	1,140
00506	30,0	58	30,0	56	2	0,430	00515	55,0	93	55,0	88	4	1,080
00507	31,8	58	31,8	56	2	0,415	00516	57,1	93	57,1	88	4	1,020
00508	34,0	65	34,0	66	4	0,570							
00509	35,0	65	35,0	66	4	0,560							

Kit perni e bulloni per fissaggio bracciali (facoltativo)
Bolts and nuts kit (available on request)

Anodi per assi Anodes for shafts

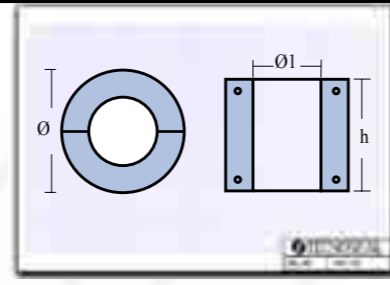
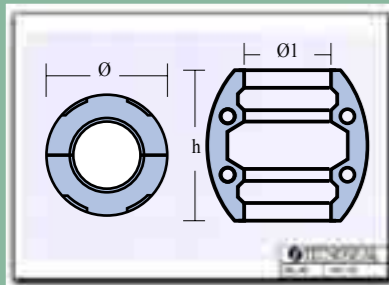

BRACCIALI PER ASSI • SHAFTS ANODES

SERIE - Ø 19-100 ASSE STANDARD STANDARD SHAFTS
Ø 100-160 A RICHIESTA - ON REQUEST

cod.	Ø asse	Ø	Ø1	h	fori	kg
00517	60,0	100	60,0	100	4	1.745
00518	63,5	100	63,5	100	4	1.640
00519	65,0	100	65,0	100	4	1.630
00520	70,0	128	70,0	107	4	2.740
00521	75,0	128	75,0	107	4	2.560
00521M	76,2	128	76,2	107	4	2.540
00522	80,0	128	80,0	107	4	2.340
00523	85,0	128	85,0	107	4	2.080

cod.	Ø asse	Ø	Ø1	h	fori	kg
00524	90,0	132	90,0	112	4	4.700
00525	95,0	142	95,0	114	4	5.580
00526	100,0	142	100,0	114	4	5.250
00528	115,0	180	115,0	156	4	15.300

Kit perni e bulloni per fissaggio bracciali (su richiesta)
Bolts and nuts kit (available on request)



BRACCIALI PER ASSI • BRACELETS FOR SHAFTS

cod.	Ø asse	Ø	Ø1	h	kg
00500L	19,0	50	19,0	40	0.305
00501L	22,0	50	22,0	40	0.270
00502L	25,0	50	25,0	40	0.250

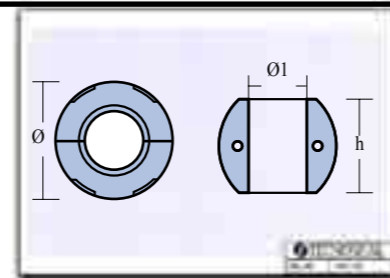

cod.	Ø asse	Ø	Ø1	h	kg
00503L	25,4	50	25,4	40	0.250
00504L	28,0	50	28,0	40	0.220

Kit perni e bulloni per fissaggio bracciali (su richiesta)
Bolts and nuts kit (available on request)

Anodi per assi Anodes for shafts

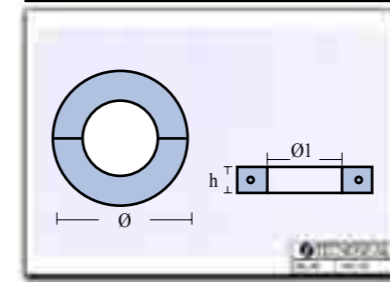

COLLARI PER ASSI • SHAFTS COLLARS
SERIE - Ø 19-100 STANDARD
Ø 100-360 A RICHIESTA - ON REQUEST

cod.	Ø asse	Ø	Ø1	h	kg
00550	19,0	65	19,0	18	0.310
00551	22,0	65	22,0	18	0.300
00552	25,0	65	25,0	18	0.280
00553	25,4	65	25,4	18	0.290
00554	28,6	65	28,6	18	0.270
00555	30,0	65	30,0	18	0.260
00556	31,8	65	31,8	18	0.250
00557	35,0	65	35,0	18	0.230
00558	40,0	80	40,0	20	0.440
00559	45,0	80	45,0	20	0.390
00560	50,0	90	50,0	25	0.595
00561	55,0	110	55,0	30	1.350
00562	38,0	65	38,0	20	0.210
00563	57,1	110	57,1	30	1.300
00564	60,0	110	60,0	30	1.250

Kit perni e bulloni per fissaggio collari (facoltativo)
Bolts and nuts kit (available on request)

cod.	Ø asse	Ø	Ø1	h	kg
00565	63,5	110	63,5	30	1.170
00566	65,0	110	65,0	30	1.150
00567 (ex 00565)	70,0	120	70,0	30	1.390
00568 (ex 00566)	75,0	120	75	30	1.260
00569 (ex 00567)	80,0	135	80	32	1.860
00570 (ex 00568)	85,0	135	85	32	1.720
00571 (ex 00570)	90,0	135	90	32	1.580
00572	95,0	135	95	32	1.400
00573	100,0	148	100	32	2.000
00575	110,0	204	110	40	6.100
00576	115,0	204	115	40	5.800
00577	120,0	204	120	40	5.690

COLLARI PER ASSI • SHAFTS COLLARS
SERIE NAVALE

cod.	Ø asse
00580	125
00583	140
00590M	300
00595	350

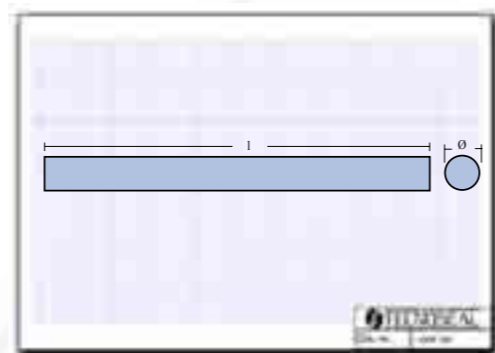
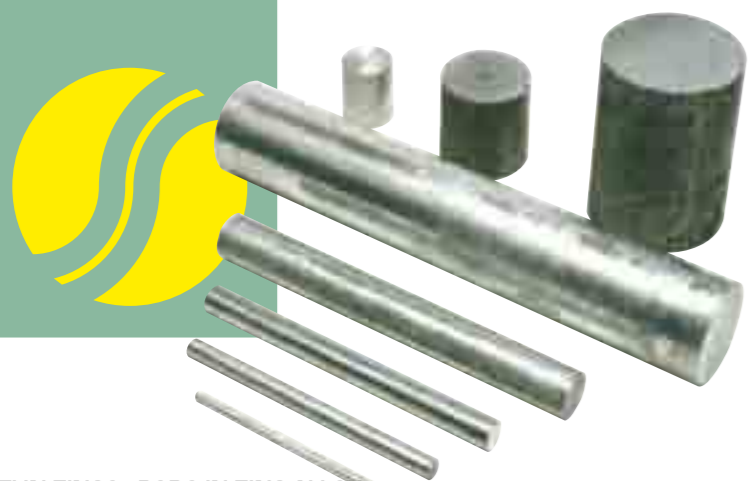

BARROTTI IN ZINCO - RODS IN ZINC ALLOY

cod.	Ø x l	kg
00600	10 x 400	0,230
00600/1	12 x 400	0,330
00600/2	14 x 400	0,440
00601	15 x 400	0,500
00601/1	16 x 400	0,610
00601/2	18 x 400	0,750
00602	20 x 400	0,900
00603	25 x 400	1,400
00604	30 x 400	2,020
00605	35 x 400	2,800
00606	40 x 400	3,580
00607	45 x 400	4,550
00607/5	45 x 500	5,670
00608	50 x 400	5,600

cod.	Ø x l	kg
00608/5	50 x 500	7,000v
00608/7	50 x 750	10,500
00609	55 x 400	6,780
00610	60 x 400	7,800
00611	65 x 400	9,450
00612	70 x 400	10,950
00612/5	70 x 500	13,700
00612/1	75 x 400	12,650
00613	80 x 400	14,350
00613/5	80 x 500	18,000
00616	85 x 400	17,800
00617	90 x 400	18,200
00617/1	90 x 500	22,700
00618	95 x 400	20,200

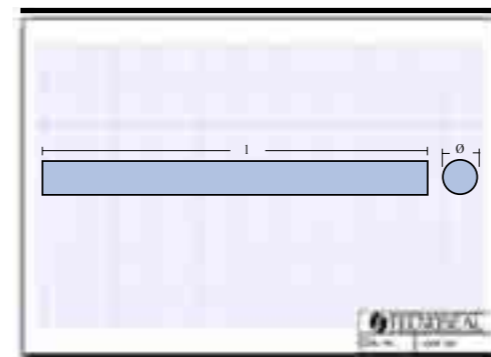

BARROTTI IN ZINCO - RODS IN ZINC ALLOY

cod.	Ø x l	kg
00614	100x400	22,550
00614/5	100 x 500	28,200
00619	110 x 400	27,000
00620	130 x 400	37,900
00621	140 x 400	43,900
00621/1	145 x 400	47,000
00622	150 x 400	50,400

cod.	Ø x l	kg
00622/5	150 x 500	63,000
00623	160 x 400	57,300
00624	170 x 400	65,000
00627	210 x 400	89,600
00629	230 x 400	123,000
00629/1	240 x 400	132,000

Anodi sospesi / Suspended anodes

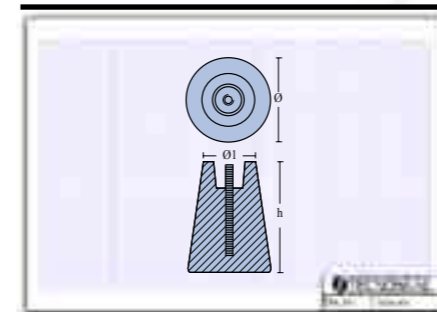

ANODO IN ZINCO • ANODE IN ZINC ALLOY

cod.	Ø	Ø1	h	kg.	cavo mt.
00630	80	53	105	2,5	4,5

ANODO IN ALLUMINIO • ANODE IN ALUMINUM ALLOY

cod.	Ø	Ø1	h	kg.	cavo mt.
00631	80	53	105	1,0	4,5



ANODO IN MAGNESIO • ANODE IN MAGNESIUM ALLOY

cod.	Ø	Ø1	h	kg.	cavo mt.
00632	80	53	105	0,9	4,5

Anodi sospesi / Suspended anodes

Barre / Bars

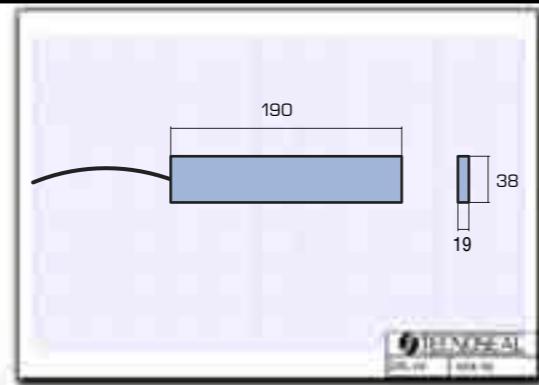

ANODO IN ZINCO • ANODE IN ZINC ALLOY
SERIE - TEC. 4

cod.	l	A	h	kg	cavo mt.
00633	190	38	19	0,9	2,5

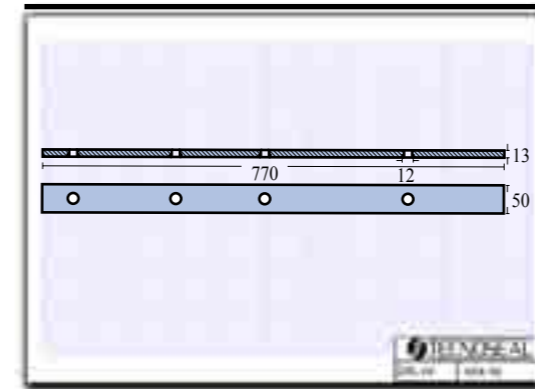

SERIE - ALISCAFI CON INSERTO
WITH STRAP

cod.	l	a	h	i	Ø	kg
00670	770	50	13	450	12	3,500

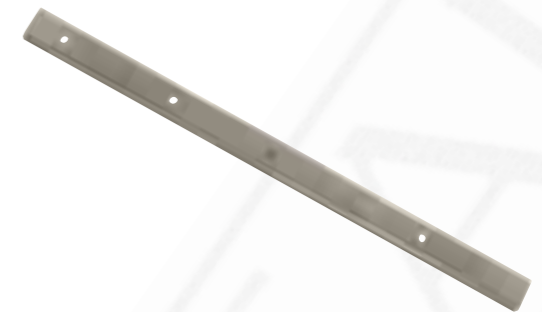

DISPONIBILE ANCHE IN MAGNESIO
AVAILABLE IN MAGNESIUM TOO

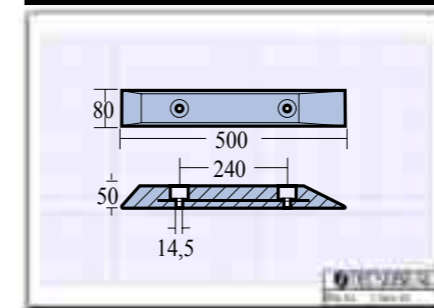

ANODI IN MAGNESIO G.D.F. • MAGNESIUM ANODES G.D.F.
SERIE - BIGLIANI

cod.	l	a	h	i	Ø	kg
00680	500	80	50	240	14,5	3,850

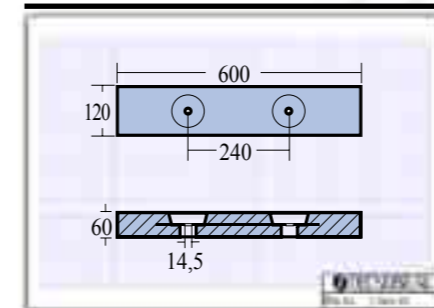

ANODI IN MAGNESIO G.D.F. • MAGNESIUM ANODES G.D.F.
SERIE - CORRUBIA II

cod.	l	a	h	i	Ø	kg
00681	600	120	60	240	14,5	7,200



Barre / Bars

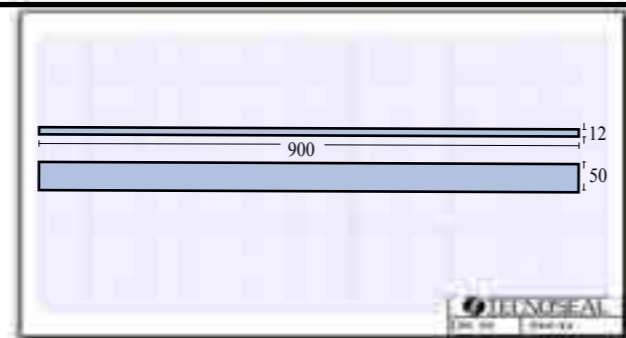

SERIE - ALISCAFI

cod.	l	a	h	i	Ø	kg
00650	900	50	12	sf	-	3,400



DISPONIBILE ANCHE IN MAGNESIO
AVAILABLE IN MAGNESIUM TOO

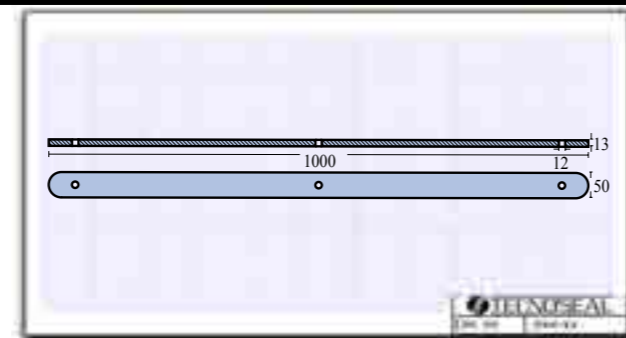

SERIE - STRYKER

cod.	l	a	h	i	Ø	kg
00660	1000	50	13	450	12	4,200



DISPONIBILE ANCHE IN MAGNESIO
AVAILABLE IN MAGNESIUM TOO

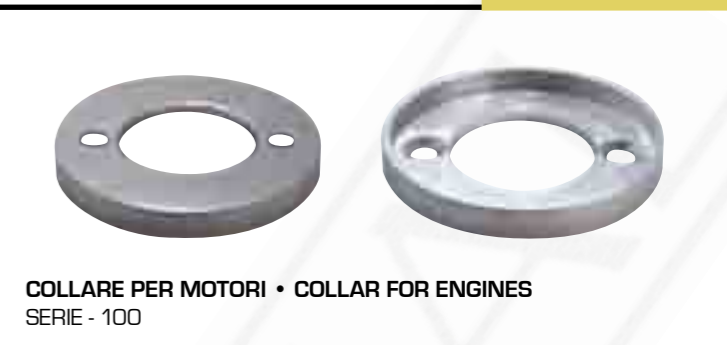
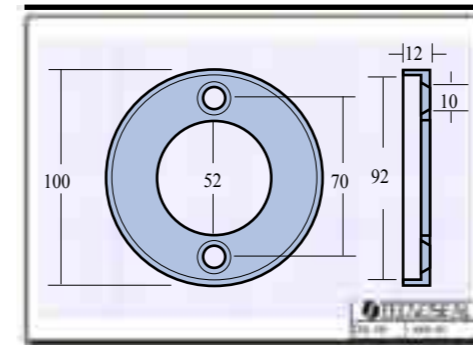

COLLARE PER MOTORI • COLLAR FOR ENGINES
 SERIE - 100

COD. KG

00700
 875810* 0,200

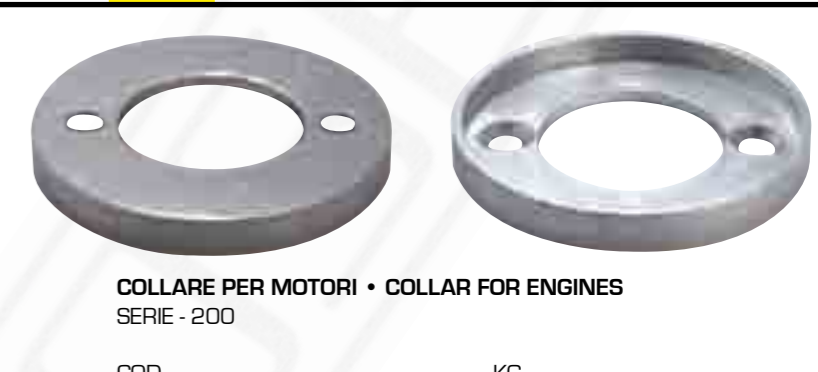
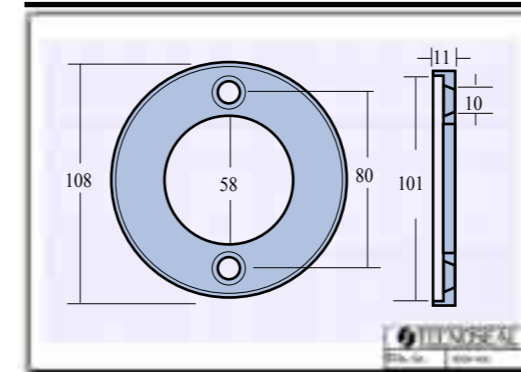

COLLARE PER MOTORI • COLLAR FOR ENGINES
 SERIE - 200

COD. KG

00701
 875809* 0,255

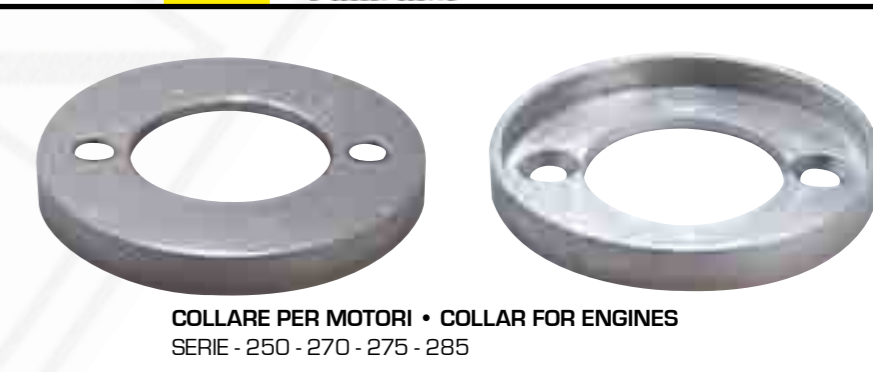
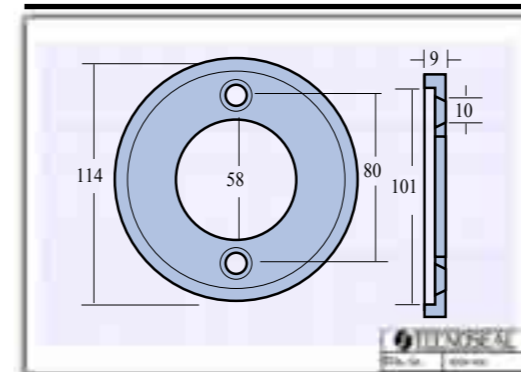

COLLARE PER MOTORI • COLLAR FOR ENGINES
 SERIE - 250 - 270 - 275 - 285

COD. KG

00702
 875806* 0,280

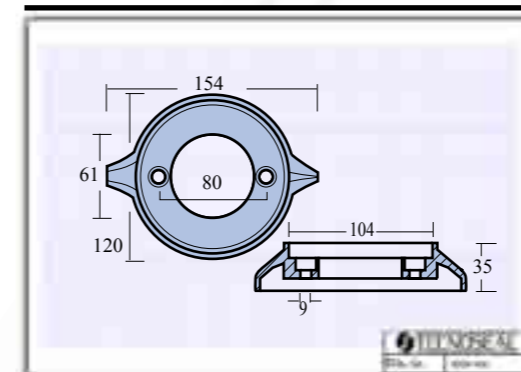

COLLARE PER MOTORI • COLLAR FOR ENGINES
 SERIE - 280 - 290 E SINGLE PROP

COD. KG

00703
 875815* 0,755

* original code



COLLARE PER MOTORI • COLLAR FOR ENGINES
SERIE - DUO PROP 290

cod. kg h

00704
875821*



0,566 35

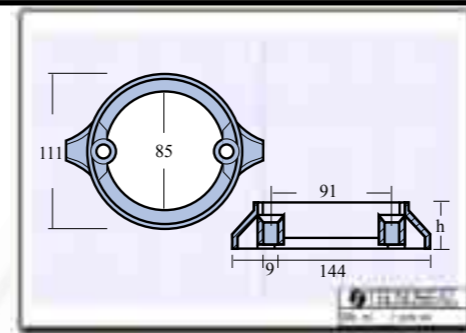

cod. kg h

00704 BIS



0,470 DAL2002 30



COLLARE PER MOTORI • COLLAR FOR ENGINES
SERIE - S. DRIVE 110

cod. kg

00705
875812*



0,940

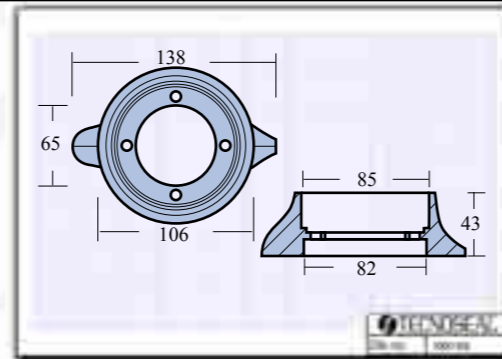

COLLARE PER MOTORI • COLLAR FOR ENGINES
SERIE - S. DRIVE 120

cod. kg

00706
876286*
851893*



0,530

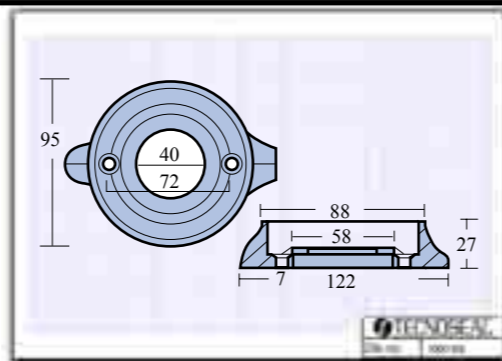

BARRA PER MOTORI • BAR FOR ENGINES
SERIE - 250-270-275-280-285

cod. kg

00707
832598*



0,930

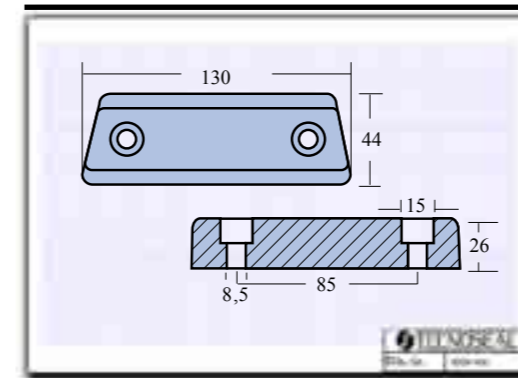
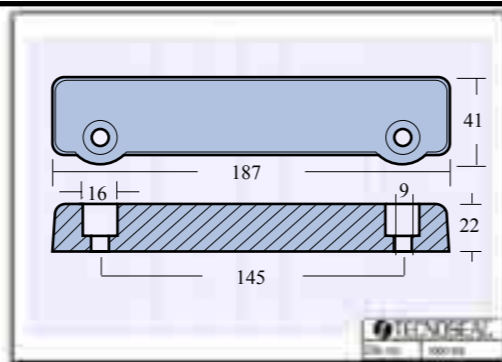

BARRA PER MOTORI • BAR FOR ENGINES
SERIE - DUO PROP 290

cod. kg

00708
852835*



0,750

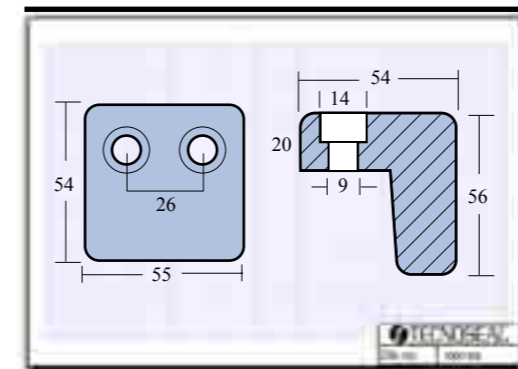

SQUADRA PER MOTORI • BRACKET FOR ENGINES
SERIE - TRIM 270

cod. kg

00709
832934*



0,630

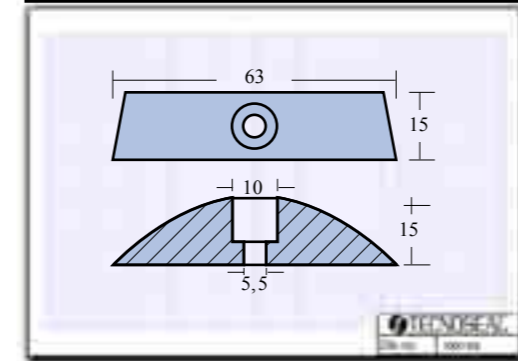
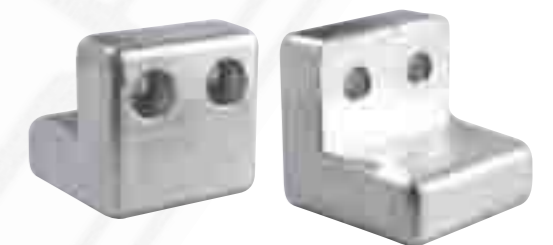

PIASTRINE PER MOTORI • PLATE FOR ENGINES
SERIE - 110, 120, S-B, S-C

cod. kg

00710
852018*



0,175 Fornito a coppia

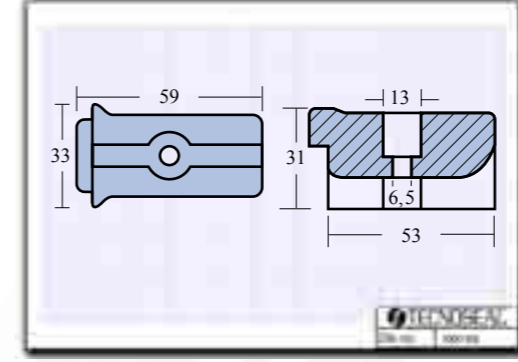

PLACCA PER MOTORI • PLATE FOR ENGINES
SERIE - S. DRIVE

cod. kg

00711
855105*



0,160



* original code

* original code



PINNA PER MOTORI • SKEG FOR ENGINES
SERIE - FB

cod. kg

00712 0,210

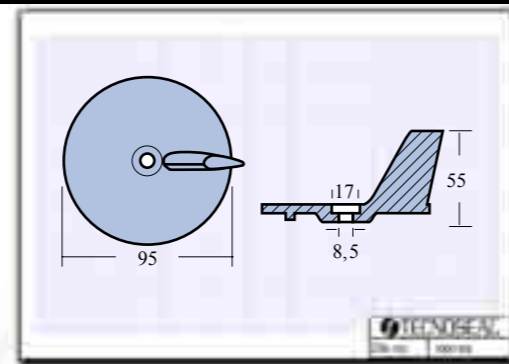

BARROTTO PER REFRIGERANTE • ROD FOR COOLER
SERIE - 200-250-270

cod. l Ø Ø1 kg

00713 40 15 7/16unc 0,060

00713T COMPLETO DI TAPPO COMPLETE WITH PLUG 0,100

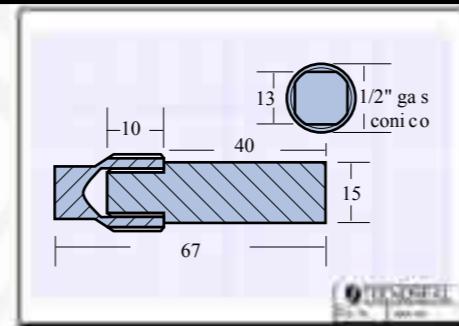

cod. l Ø Ø1 kg

00713TP SOLO TAPPO PLUG ONLY 0,040



BARROTTO PER REFRIGERANTE • ROD FOR COOLER

cod. l Ø Ø1 Ø2 kg

00714 30 16 7/16unc 8ma 0,035

00714T COMPLETO DI TAPPO COMPLETE WITH PLUG 0,080

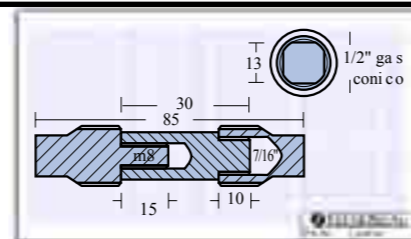

cod. l Ø Ø1 kg

00714TPM SOLO TAPPO MASCHIO MALE PLUG ONLY 0,060

00714TPF SOLO TAPPO FEMMINA FEMALE PLUG ONLY 0,040



BARROTTO PER REFRIGERANTE • ROD FOR COOLER

cod. l Ø Ø1 kg

00715 13 16 5/16unc 0,020

00716 44 25 3/8"unc 0,155

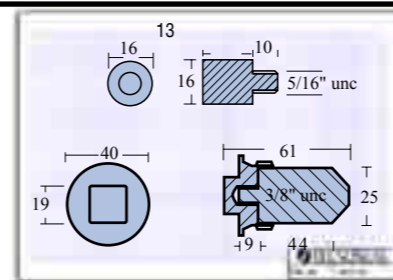

cod. l Ø Ø1 kg

00716T COMPLETO DI TAPPO COMPLETE WITH PLUG 0,255

00716TP SOLO TAPPO 1" GAS GAS PLUG ONLY 0,095

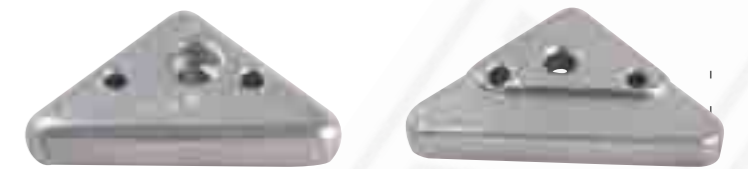
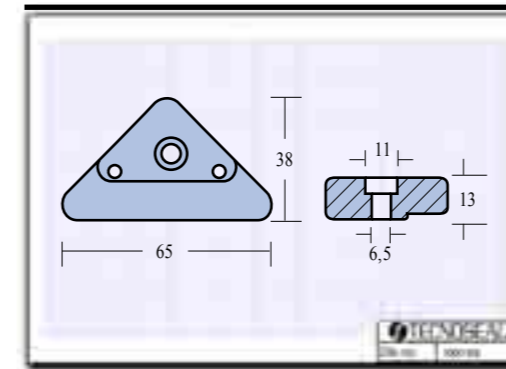

PLACCA DUO VOLVO • PLATE FOR DUO PROP 290

cod. kg

00717 872793* 0,110

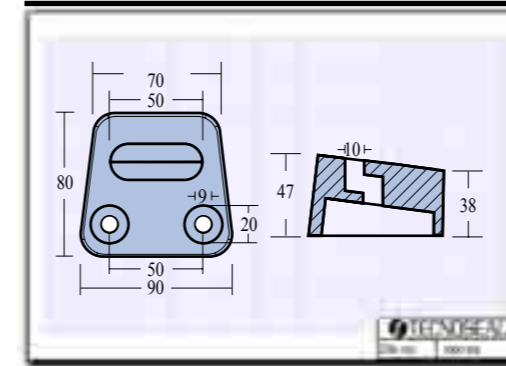

PLACCA MOTORI • PLATE FOR ENGINES
SERIE - S. DRIVE - SX DRIVE

cod. kg

00718 3854130* 1,050

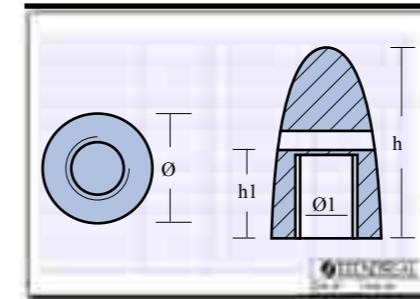

cod. Ø asse Ø1 kg h Ø h1

00719 833913* 25/30 3/4"unc 0,305 70 37 33

00720 833915* 35 7/8"unc 0,275 70 37 33



DADI PER ASSE - SHAFT NUTS

cod. Ø asse Ø1 kg h Ø h1

00721 828140* 40 1" unc 0,485 80 47 35

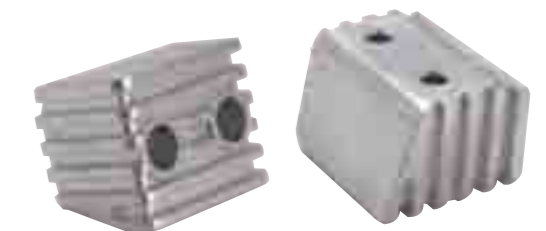
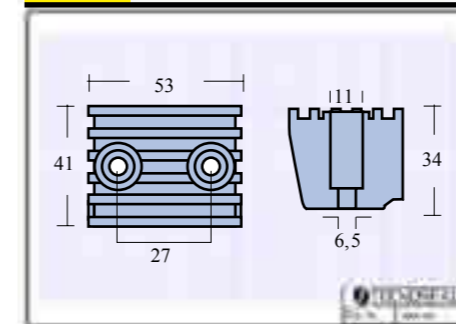

CUBO PER MOTORI • PLATE FOR ENGINES
SERIE - DPX

cod. kg

00722 873395* 0,370

* original code

* original code

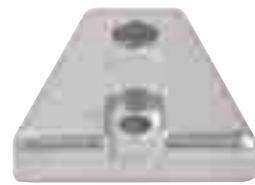

PLACCA PER MOTORI • PLATE FOR ENGINES
SERIE - DPX

cod. kg

00723
876638* 0,215

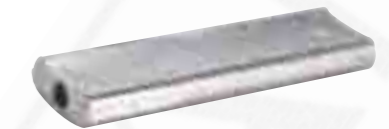
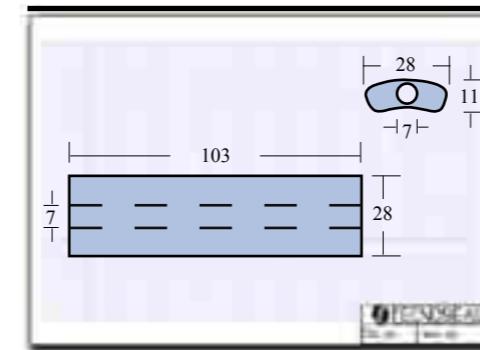
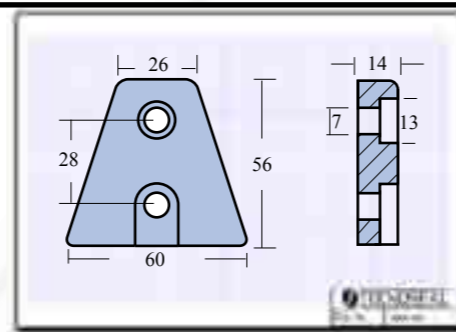

BARRA PER MOTORI • BAR FOR ENGINES SX

cod. kg

00727
3852970* 0,160



BARRA PER MOTORI • BAR FOR ENGINES
SERIE - DPX

cod. kg

00724
872139* 0,690

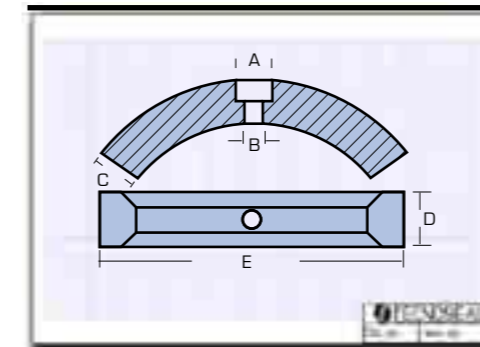
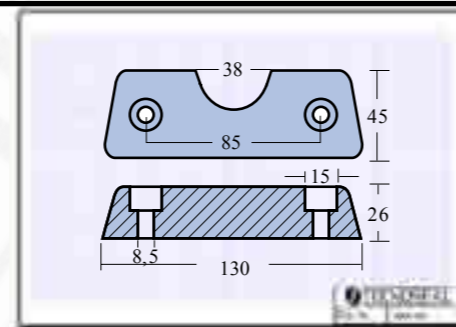

COLLARE PER ELICA TRE PALE ABB • COLLAR FOR PROPELLER

cod. A B C D E kg

00728
3858399* 10 5,5 12 15 83 0,300

COLLARE ELICA 3 PALE S DRIVE E 4 PALE ABB • COLLAR FOR PROP.

cod. A B C D E kg

00728BIS
3584442* 10 5,5 9 15 97,50 0,276



PINNA PER MOTORI • SKEG FOR ENGINES

cod. kg

00725
0,430

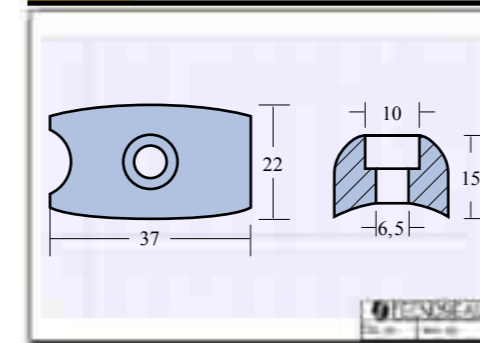
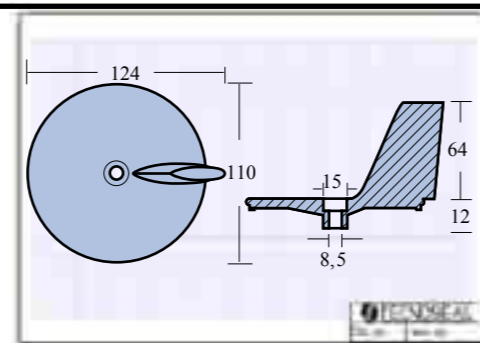

PLACCA BOW THRUST SEAL DRIVE
PLATE FOR BOW THRUST SEAL DRIVE

cod. kg

00729
0,045

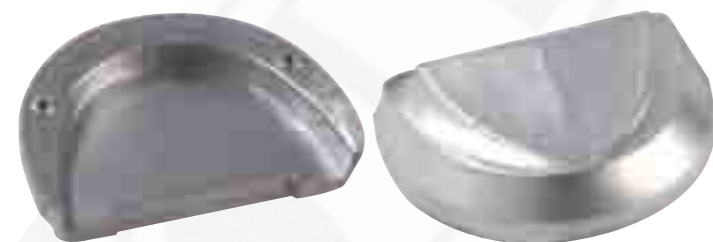

PLACCA PER MOTORI • PLATE FOR ENGINES SX DRIVE

cod. kg

00726
3855411* 0,940

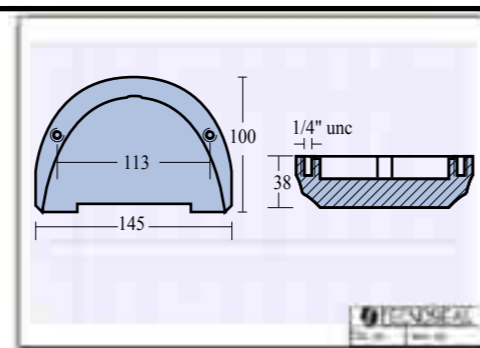

* original code

* original code

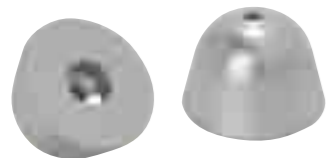

OGIVA PER BOW THRUST • OGIVE FOR BOW THRUST

cod. kg

00731 0,060

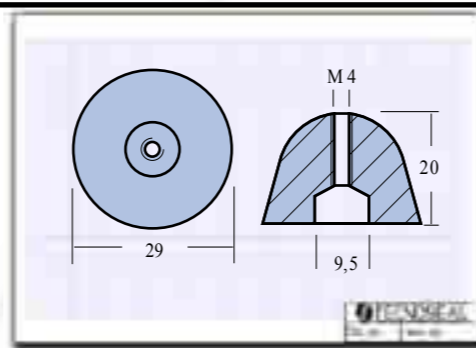

PIASTRA VOLVO PENTA • PLATE FOR STERN DRIVE VOLVO PENTA

cod. kg

00732 0,088

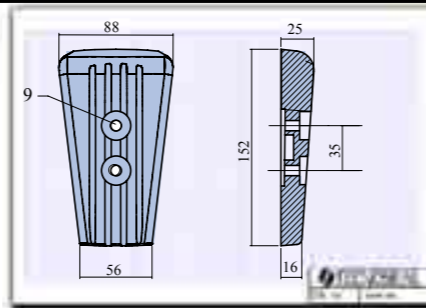
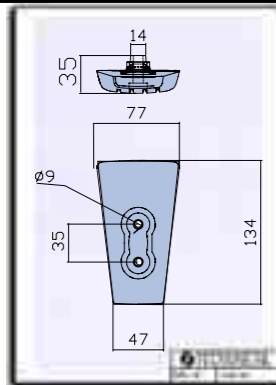
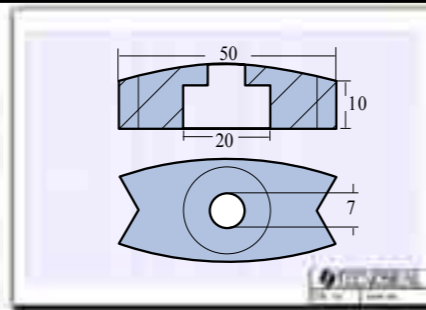

PIASTRA VOLVO PENTA • PLATE FOR STERN DRIVE VOLVO PENTA
SERIE - DPH/DPR

cod. kg

00733 0,850



PIASTRA PER PIEDE POPPIERO VOLVO PENTA
PLATE FOR STERN DRIVE VOLVO PENTA
SERIE - SX DPH/DPR

cod. kg

00733BIS 1,270



COLLARE PER PIEDE POPPIERO
COLLAR FOR BACKBOARD 130/150 SAIL DRIVE
2002 2003

cod. kg

00734 1,460

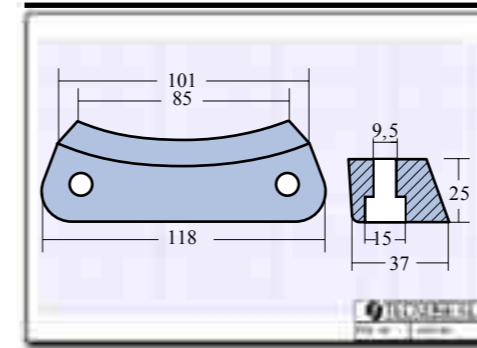
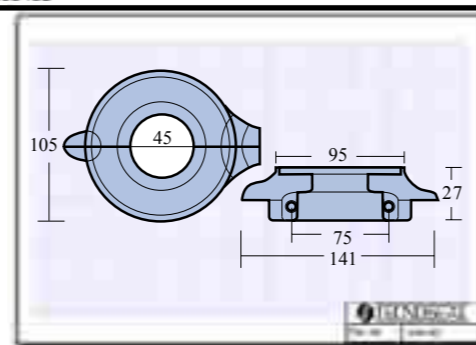

BARRA PER MOTORI • BAR FOR ENGINES
SERIE - DUO PROP

cod. kg

00735 0,515

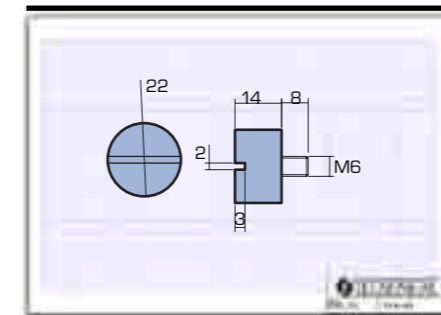

BARROTTO PER SCAMBIATORE DI CALORE
BAR FOR COOLER
SERIE - SEAL DRIVE 100

cod. kg

00736 0,035

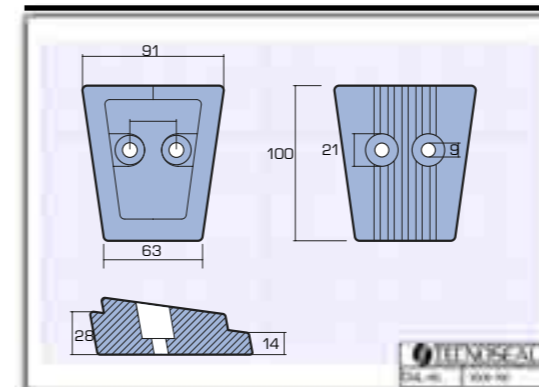

PIASTRA PER MOTORI • PLATE FOR ENGINES
SERIE - SX 19 N ZINCO
SU RICHIESTA VERSIONE IN ALLUMINIO
AVAILABLE IN ALUMINUM

cod. kg

00737 1,150

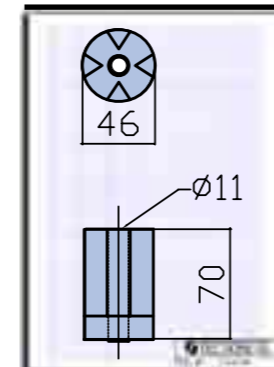

ANODO PER MOTORI • STAR ZINC ANODE
SERIE - IPS

cod. kg

00738 0,740

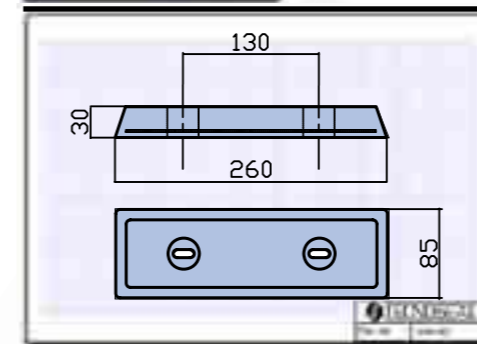

ANODO PER MOTORI • ANODE FOR ENGINES
SERIE - IPS

cod. kg

00739AL 1,600



* original code

* original code



KIT SERIE VOLVO 280



KIT SERIE VOLVO DUO-PROP 280

cod.

cod.

KITVOLV0280 N° 1 pz 00703 - N° 1 pz 00707

KITVOLVODP280 N° 1 pz 00707 - N° 1 pz 00704BIS



KIT SERIE VOLVO SX



KIT SERIE VOLVO 290

cod.

cod.

KITVOLVOSX N° 1 pz 00718 - N° 1 pz 00726

KITVOLV0290 N° 1 pz 00703 - N° 1 pz 00708



KIT SERIE VOLVO DUO-PROP 290



KIT SERIE VOLVO SXA/DPSA - SERIES

cod.

cod.

KITVOLVODP290 N° 1 pz 00704BIS - N° 1 pz 00708

KITVOLVOSXA/DPSA N° 1 pz 00733BIS - N° 1 pz 00737



KIT SERIE VOLVO DPH/DPR - SERIES



KIT SERIE VOLVO IPS SERIES

cod.

cod.

KITVOLVODPH/DPR N° 1 pz 00733 - N° 1 pz 00735

KITVOLVOIPS N° 1 pz 00738 - N° 1 pz 00739



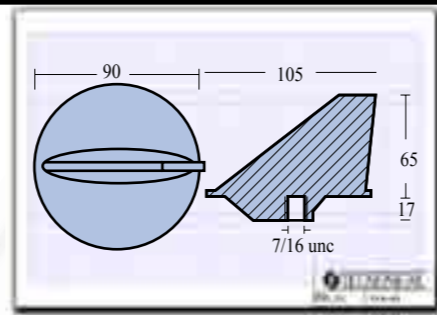

PINNA CORTA PER MOTORI • SHORT SKEG FOR ENGINES
SERIE - MERCURY 50 HP

cod. kg

00800 7/16"unc 0,480

3164034*
316404*

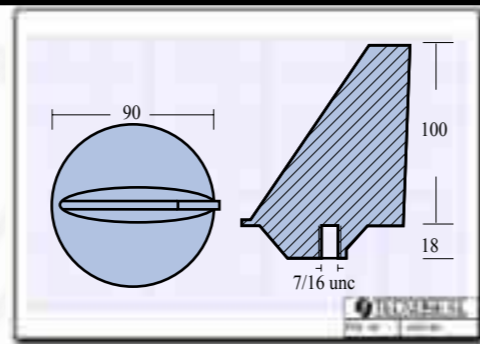

PINNA LUNGA PER MOTORI • LONG SKEG FOR ENGINES
SERIE - MERCURUISER 80 - 140 HP

cod. kg

00801 7/16"unc 0,600

34127A1*

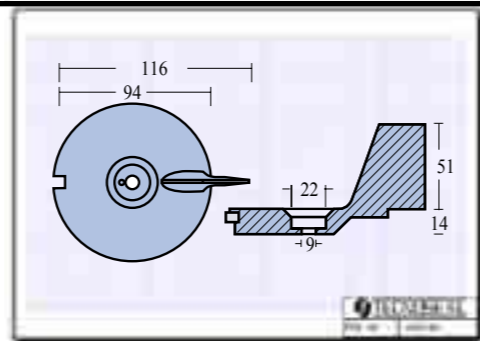

PINNA PER MOTORI • SKEG FOR ENGINES
SERIE - MERCURY 25 HP

cod. kg

00802 0,265

94285T1*

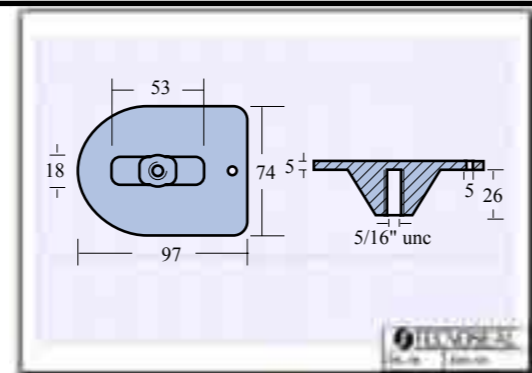

PIASTRA PER MOTORI • PLATE FOR ENGINES
SERIE - MERCURY 20 HP

cod. kg

00803 5/16"unc 0,310

47820A1*



* original code

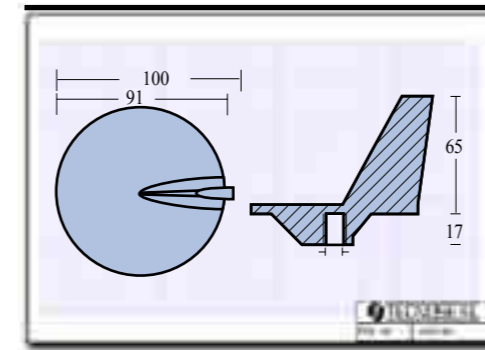

PINNA PER MOTORI CON ELICA GRANDE
SKEG FOR ENGINES WITH LARGE PROPELLER
SERIE - 50 - 140 HP

cod. kg

00804 7/16"unc 0,395

46399*

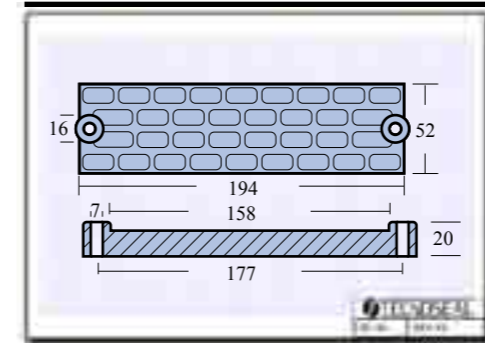

PIASTRA PER MOTORI • WAFFLE BAR
SERIE - MERCURY 25 HP / 50/60/75
MERCURUISER E.B. 90/100 SINO 91 115/190
SUPERAMERICA 80/115

cod. kg

00805 0,665

43396*

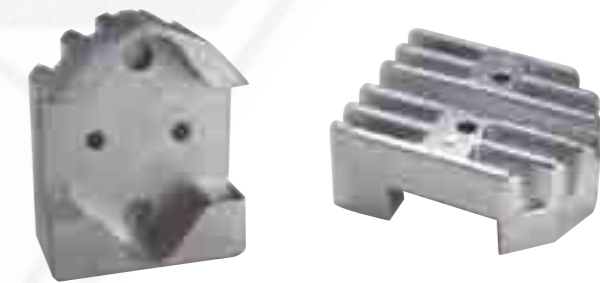
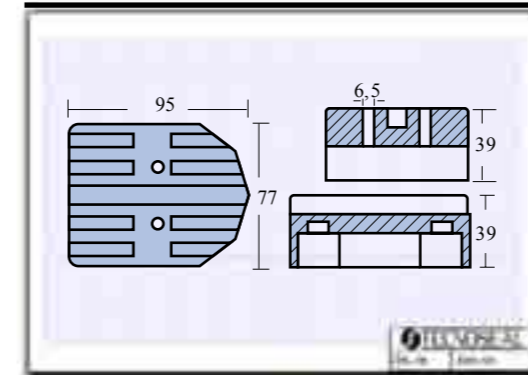

PLACCA PER MOTORI • BLOCK
SERIE - MERCURY F.B.B - MERCURUISER E.B.
ALPHA GEN II + BRAVO

cod. kg

00806 0,895

43994*

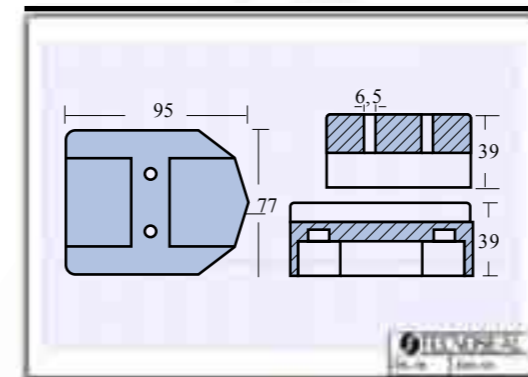

PLACCA PER MOTORI • BLOCK
SERIE - MERCURY F.B.B - MERCURUISER E.B.

cod. kg

00806BIS 0,890

821631A1
821631Q1*



* original code



DADO PER MOTORI • NUT FOR ENGINES
SERIE - ALPHA ONE - BRAVO ONE

cod. kg

00807 1/2" unc 0,120
55989*

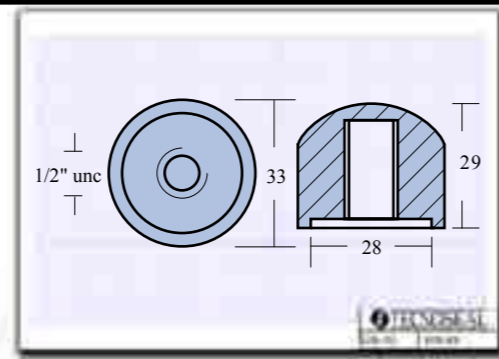

PIASTRINA PER MOTORI • PLATE FOR ENGINES

cod. mm kg

00808 64 x 64 x 10 0,270
34762*

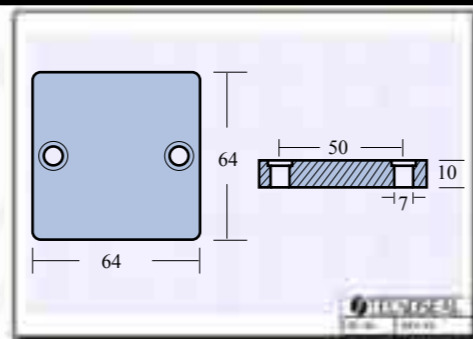

PIASTRINA PER MOTORI • PLATE FOR ENGINES
SERIE - MERCURY 4,5-9 HP

cod. kg

00809 sino 1987 0,030
85824A3*

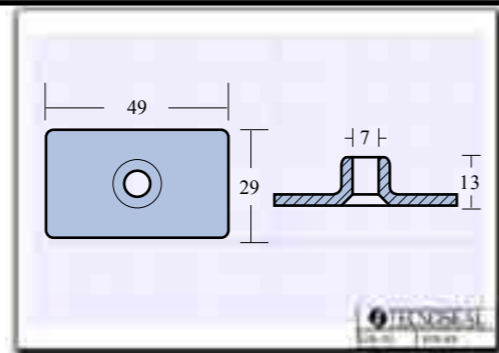

PIASTRINA PER MOTORI • PLATE FOR ENGINES
SERIE - MERCURY 6-9,9 HP

cod. kg

00810 0,030
42121A_2*

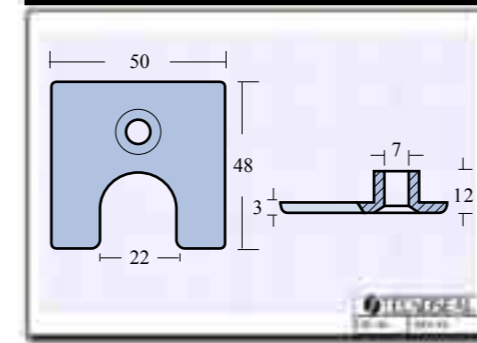
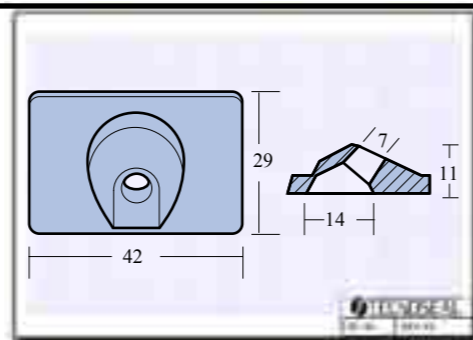

PIASTRINA PER MOTORI • PLATE FOR ENGINES
SERIE - MERCURY 4,5 - 7 HP

cod. kg

00811 0,050
08411*

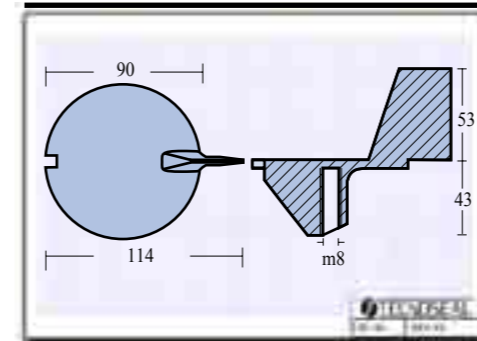

PINNA PER MOTORI • SKEG FOR ENGINES
SERIE - AMERICA 25HP (DAL 1990)

cod. kg

00812 M8 0,350
98432T5*
98432Q6*

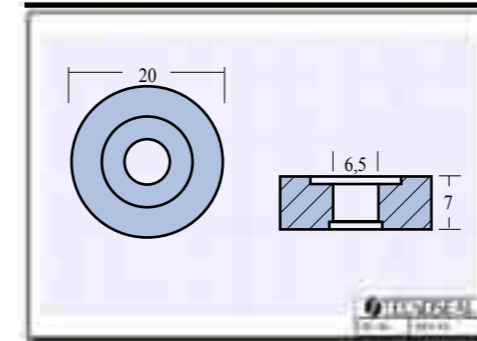

RONDELLA PER MOTORI • ENGINE WASHER
SERIE - MERCURY - NISSAN - TOHATSU 4,5 HP

cod. kg

00813 0,010
823912_1*
823912002*

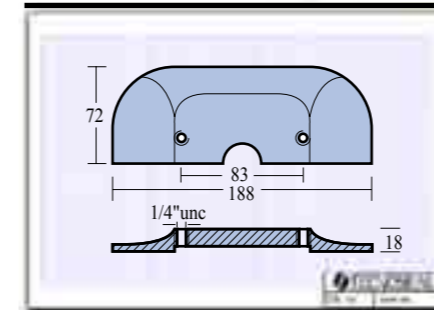

PIASTRA ANTICAVITAZIONE PER MOTORI • CAVITATION PLATE
SERIE - ALPHA ONE - ALPHA II GEN.

cod. kg

00814 0,700
821629A1*
815933*



* original code

* original code

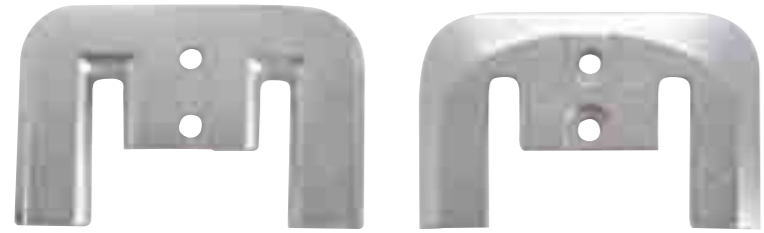

PIASTRA ANTICAVITAZIONE PER MOTORI • CAVITATION PLATE
SERIE - BRAVO I / II / III

cod. kg

00815 0,980

821630A1*
817373A1*

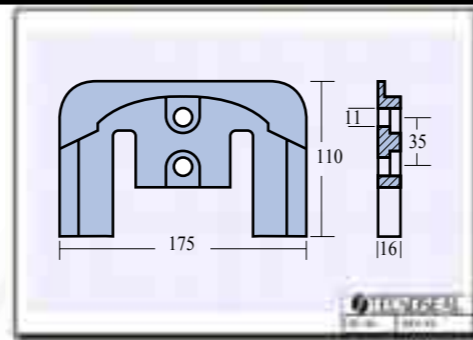

COLLARE PER MOTORI - COLLAR FOR ENGINES
SERIE - MERCUISER ALPHA ONE ALPHA II GEN.

cod. kg

00819 0,230

806105A1*
806105Q1*

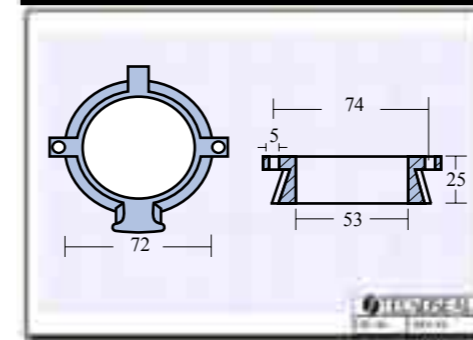

PIASTRA PER MOTORI TRIM • PLATE FOR ENGINES TRIM
SERIE - DA 40 HP A V6 135/150/175 VERADO

cod. kg

00816 0,640

818298A1*

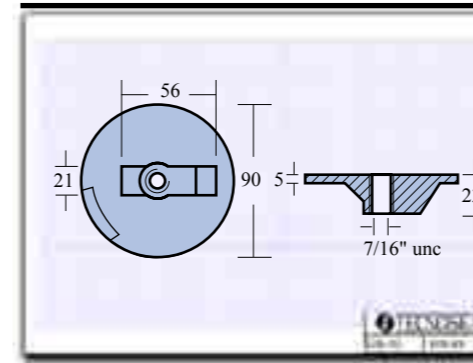
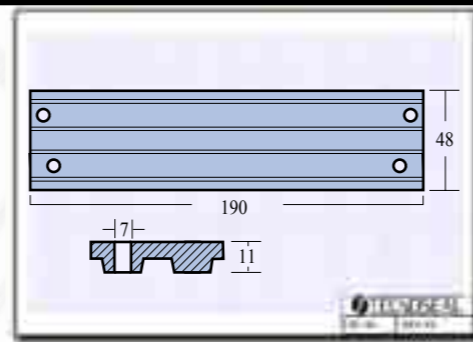

PIASTRA PER MOTORI • PLATE FOR ENGINES
SERIE - MERCURY ALPHA

cod. kg

00820 0,335

76214A5*
76214Q5*



PLACCA PER MOTORI • PLATE FOR ENGINES
SERIE - 150/200HP

cod. kg

00821 1,180

89949*

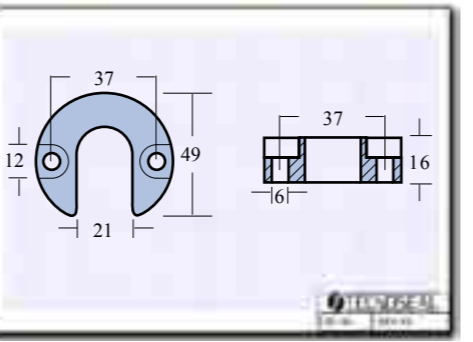
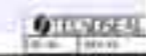
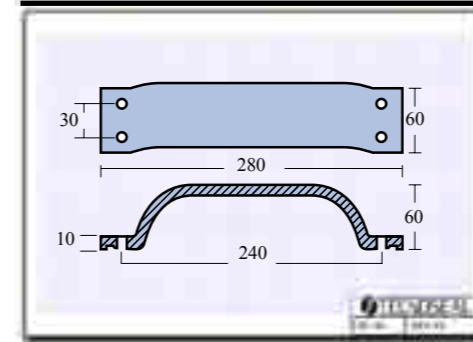

COLLARE PER TRIM - COLLAR FOR TRIM
SERIE - PISTONI MERCUISER ALPHA

cod. kg

00817 0,120

806189*

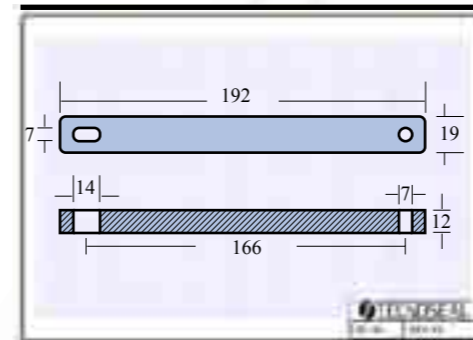

PIASTRA PER MOTORI • PLATE FOR ENGINES
SERIE - 30/40HP

cod. kg

00822 0,300

825271-1*

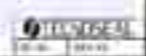
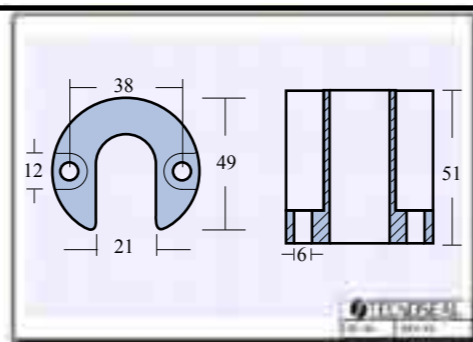

COLLARE PER TRIM - COLLAR FOR TRIM
SERIE - PISTONI MERCUISER BRAVO

cod. kg

00818 0,340

806190*



* original code

* original code



RONDELLE PER MOTORI • WASHERS FOR ENGINES

cod.	Ø	Ø1	h	kg
00823 823912*	20	7,0	7	0,010

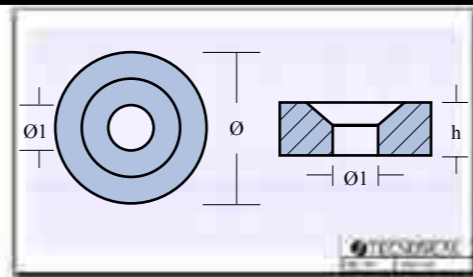

cod.	Ø	Ø1	h	kg
00824 823913*	24	6,5	6,5	0,020



PIASTRINA PER MOTORI • PLATE FOR ENGINES
SERIE - 75HP-V6 40/50/115 EFI 4T

cod.	kg
00825 826134*	0,240

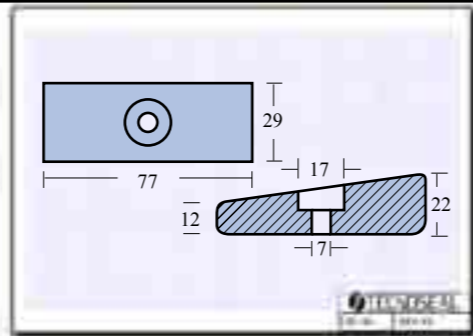

PIASTRA PER MOTORI • PLATE FOR ENGINES
SERIE - VERADO E BRAVO

cod.	Ø	kg
00826 76214*	112	0,310

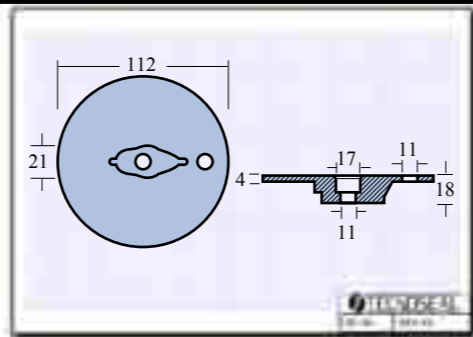

PINNA PER MOTORI • SKEG FOR ENGINES
SERIE - FORMULA 60 HP

cod.	kg
00827 17264T 2*	0,510

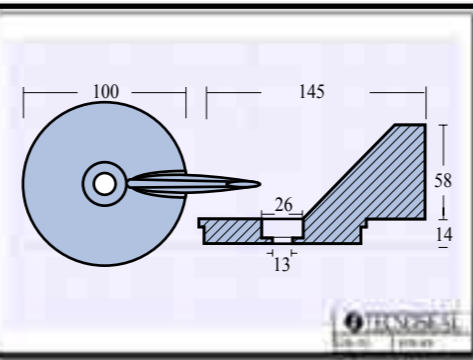

COLLARE SUPPORTO ELICAI • COLLAR FOR ENGINES
SERIE - BRAVO I E BRAVO III

cod.	kg
00828 806188*	0,170

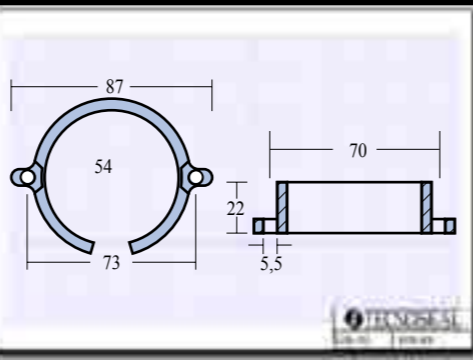

* original code

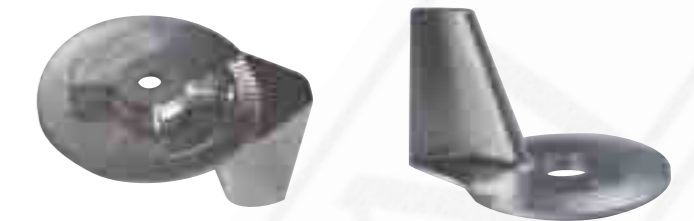
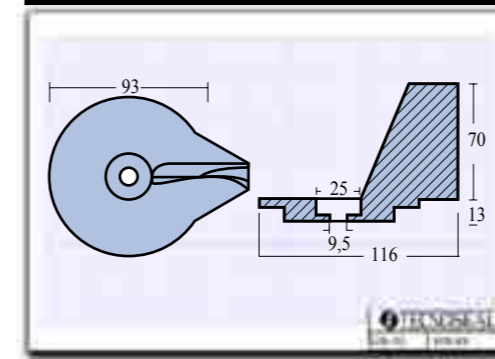

PINNA PER MOTORI • SKEG FOR ENGINES F25-F50

cod.	kg
00829 82215712*	0,435

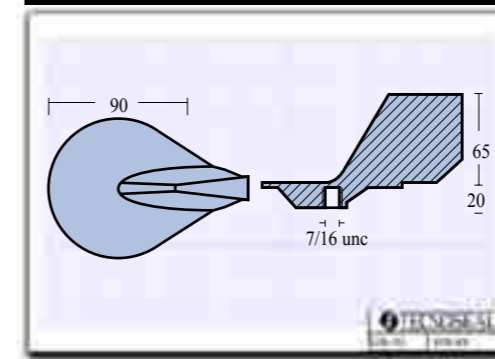

PINNA PER MOTORI • SKEG FOR ENGINES
SERIE - DA 35 HP A V6 E MCM

cod.	kg
00830 82277A1*	7/16" unc 0,680

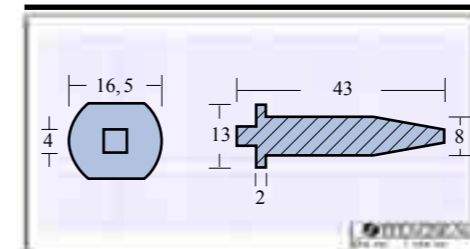

BARROTTO PER MOTORI
BAR FOR ENGINES

cod.	l	Ø	kg
00831	43	8	0,015

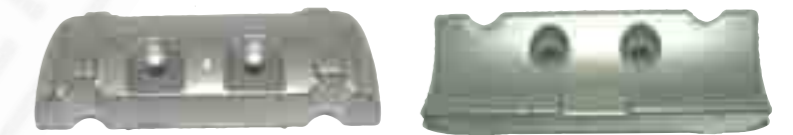
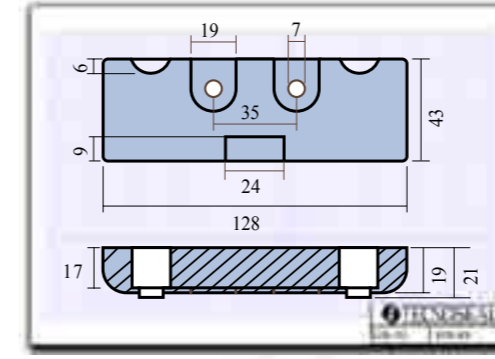

PIASTRINA MOTORE VERADO 215-275 (2 PER MOTORE)
ENGINE PLATE FOR VERADO 215-275 (2 FOR ENGINE)

cod.	kg
00832 880653*	0,485

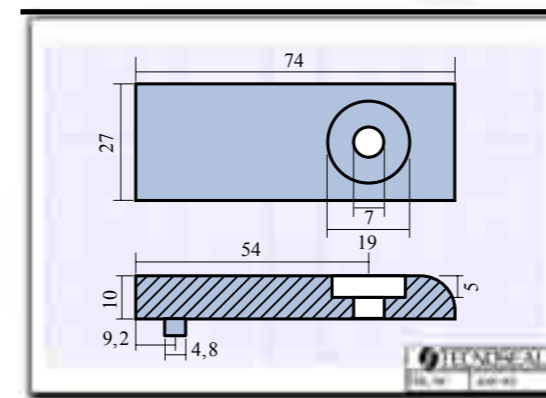

PIASTRINA MOTORE VERADO 215-275 (4 PER MOTORE)
ENGINE PLATE FOR VERADO 215-275 (4 FOR ENGINE)

cod.	kg
00833 883404*	0,110

* original code

PIASTRINA MOTORE MOTORI 4T 4 - 9.9 HP
ENGINE PLATE

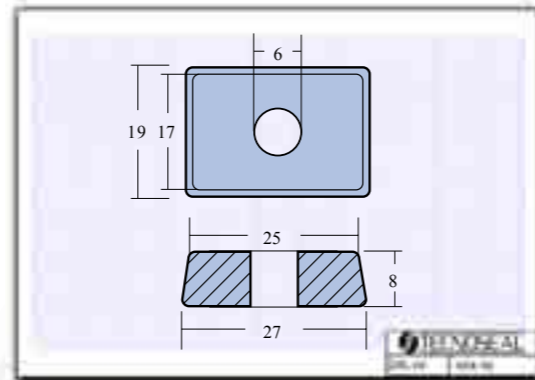

cod. _____ kg

00834
875208*  0,28

PIASTRA PER MOTORI • ENGINE PLATE

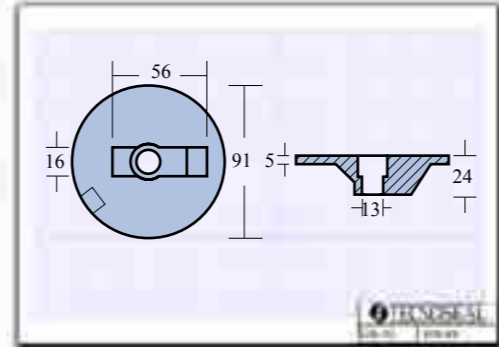

cod. _____ kg

00835
762144*  0,260

OGIVA PER BRAVO 3 • CONE NUT ANODE BRAVO 3

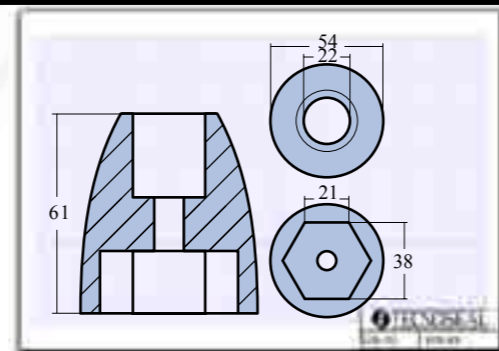

cod. _____ kg

00836
865182A1*  0,515

BARRA IN ALLUMINIO PER MOTORI • ALUMINUM BAR ANODE
VERADO 350 CI - 6 CILINDRI - 4 TEMPI

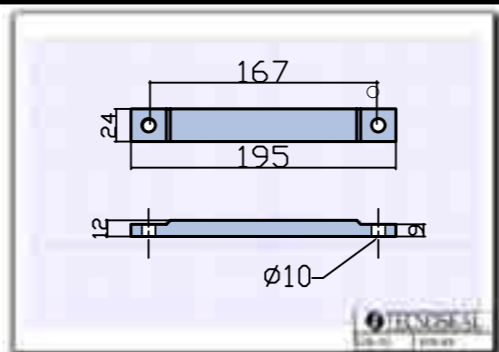

cod. _____ kg

00837AL
8M0012083*  0,130

FLANGIA IN ALLUMINIO PER VERADO • ALUMINUM ANODE
VERADO 350 CI - 6 CILINDRI - 4 TEMPI

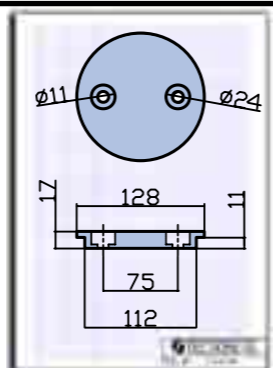

cod. _____ kg

00838AL
847635001*  0,395

* original code



KIT MERCURY ALPHA ONE

cod. _____

KITALPHAONE
888756Q01 

N°1 pz 00806bis N°2 pz 00817
N°1 pz 00814 N°1 pz 00820
N°1 pz 00819



KIT MERCURY BRAVO ONE

cod. _____

KITBRAVOI
888756Q01 

N°1 pz 00815 N°1 pz 00820
N°1 pz 00828 N°2 pz 00818



KIT MERCURY BRAVO II - III

cod. _____

KITBRAVOII-III
888761Q01 

N°1 pz 00815 N°1 pz 00820
N°2 pz 00818



KIT MERCURY BRAVO III - 2004

cod. _____

KITBRAVOIII-04
888761Q02 

N°1 pz 00835 N°1 pz 00820
N°2 Pz 00818 N°1 pz 00836
N°1 pz 00815



KIT MERCURY VERADO 4

cod. _____

KITVERADO4

N°1 pz 00820 N°2 pz 00825
N°1 pz 00816



KIT MERCURY VERADO 6

cod. _____

KITVERADO6

N°4 pz 00833 N°1 pz 00832
N°1 pz 00820 N°2 pz 00825

* original code



00900

00901

00902

00903

00904

00905

00906

00907

00908

00909

00910

00911

00912

00913

00914

00915

00916

00917

00918

00919

00920

00921

00922

00923

00925

00926

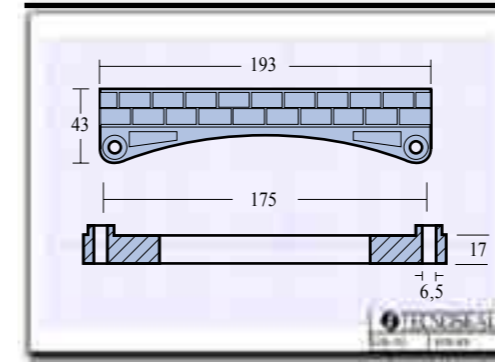

PIASTRA PER MOTORI • WAFFLE BAR
SERIE OMC P

cod. kg

00900
976669*



0,465

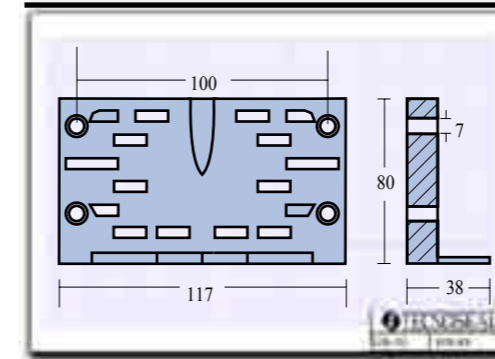

PIASTRA PER MOTORI • WAFFLE BLOCK
SERIE - OMC M (100-245 HP)

cod. kg

00901
982277*



0,580

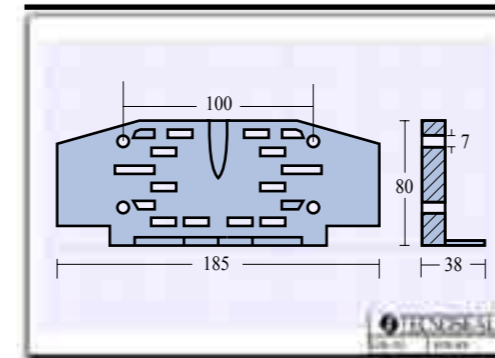

PIASTRA PER MOTORI • WAFFLE BLOCK
SERIE - OMC G (100-245 HP)

cod. kg

00902
982438*



0,970

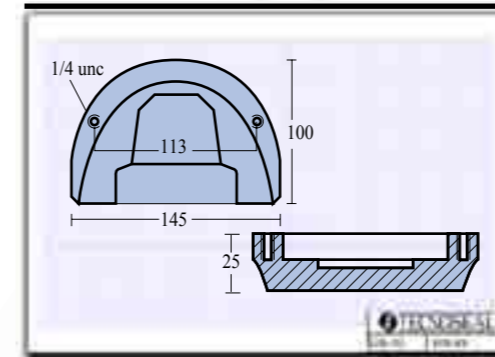

PIASTRA PER MOTORI • HORSESHOE
SERIE - OMC COBRA

cod. kg

00903
3853818*



0,980

* original code



PIASTRA PER MOTORI • BLOCK
SERIE - OMC COBRA 130-385 HP

cod. kg

00904 1,285
983952*

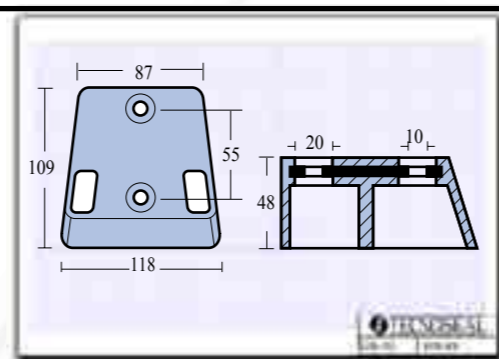

PINNA ORIENTABILE PER MOTORI • ROTARY SKEG FOR ENGINES
SERIE - OMC E.B. - F.B. - 55 HP

cod. kg

00905 0,435

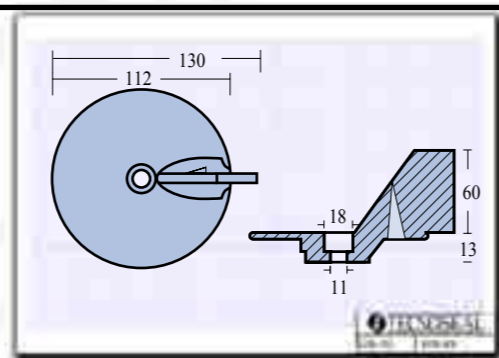

PIASTRA PER MOTORI • HORSESHOE
SERIE - OMC 90 HP

cod. kg

00906 0,725
983494*

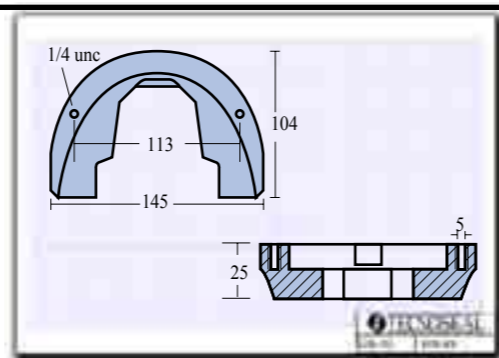

CUBO PER MOTORI • CUBE FOR ENGINES
SERIE - OMC 50-60-70-90-140 HP JOHNSON 50-115-120-140 HP
EVINRUDE 50-140-200 HP

cod. kg

00907 0,245
436745*

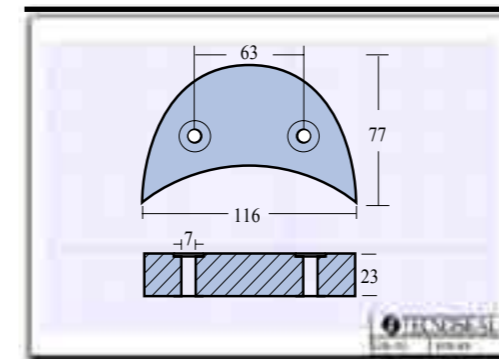
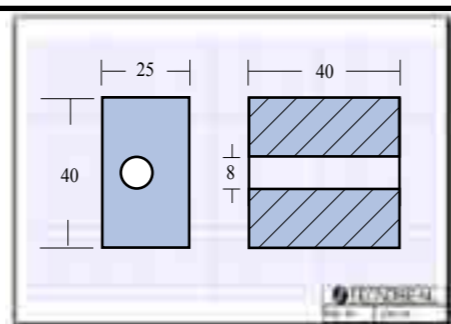

PIASTRA PER MOTORI • HALFMOON
SERIE - OMC 90-140 HP JOHNSON 90-140 HP EVINRUDE 90-140 HP

cod. kg

00908 0,820
392123*

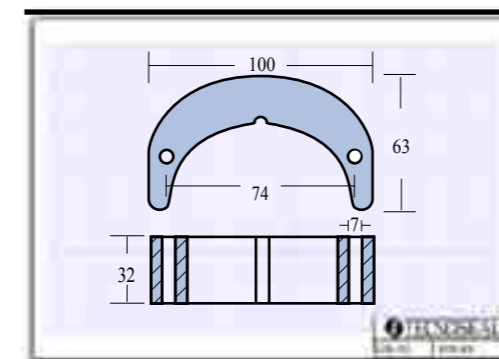

PIASTRA PER MOTORI • HORSESHOE
SERIE - OMC 50-75 HP JOHNSON 50-75 HP EVINRUDE 50-75 HP

cod. kg

00909 0,700
392462*

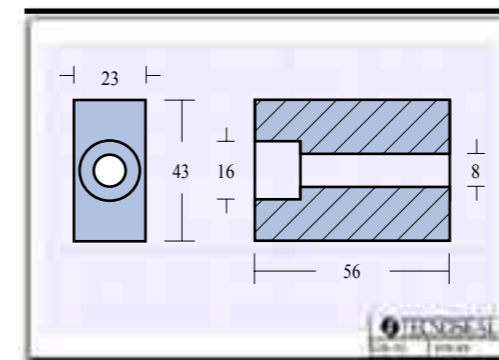

CUBO PER MOTORI • CUBE FOR ENGINES
SERIE - JOHNSON 160-280 HP (V4-V6) EVINRUDE

cod. kg

00910 0,330
433458*

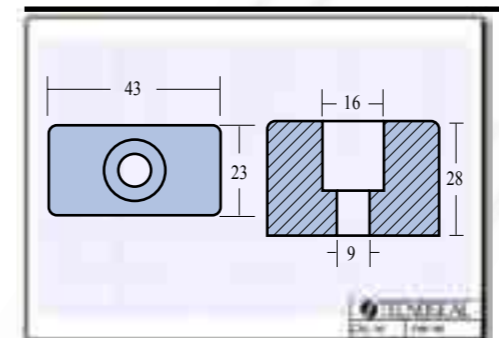

CUBO PER MOTORI • CUBE FOR ENGINES
SERIE - OMC COBRA

cod. kg

00911 0,190



* original code

* original code



PIASTRINA PER MOTORI • PLATE FOR ENGINES
SERIE - JOHNSON 2-150 HP

cod. kg

00912
173029* 0,075

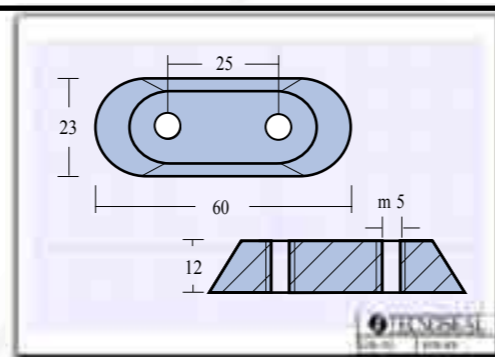

PLACCA PER MOTORI • PLATE FOR ENGINES
SERIE - JOHNSON 4-7,5 HP EVINRUDE 4-7,5 HP

cod. kg

00913
432397* 0,075

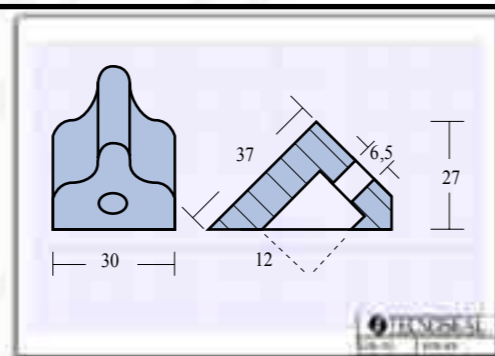

PIASTRE PER MOTORI • PLATES FOR ENGINES
SERIE - JOHNSON 521 20-25 HP 1991 EVINRUDE 20-25 HP 1991

cod. kg

00914
434029* senza vite 0,190



cod. kg

00914/1
434029* completo di vite 0,195

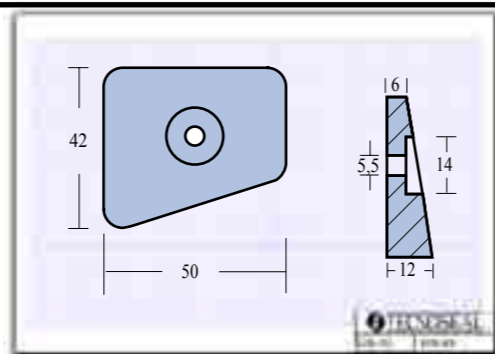

COLLARINO PER MOTORI • COLLAR FOR ENGINES
SERIE - JOHNSON 737

cod. kg

00915
398873* 0,155

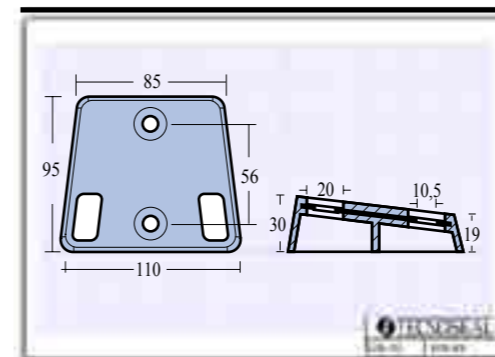
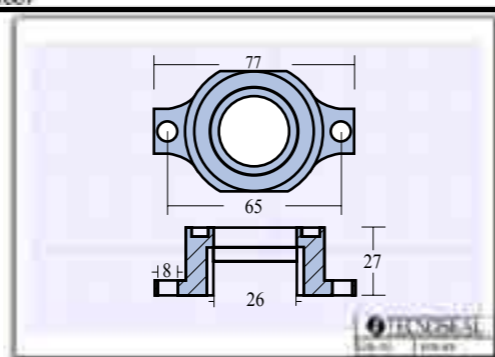

PLACCA PER MOTORI • BLOCK
SERIE - OMC COBRA BASSA

cod. kg

00916
984547* 0,800

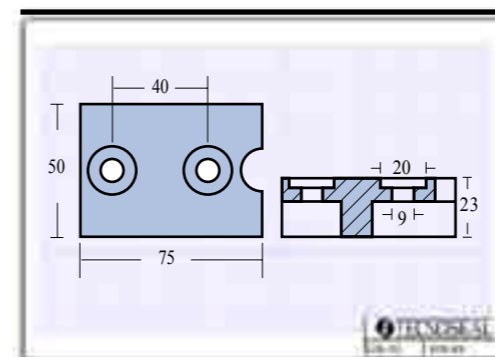

PLACCA PER MOTORI • CURVED BLOCK
SERIE - JOHNSON - EVINRUDE DIABOLO 70-120 HP

cod. kg

00917
431708* 0,300

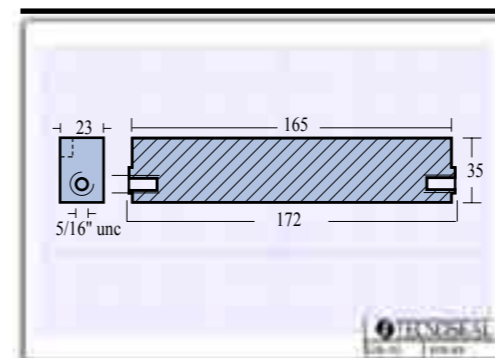

BARRA PER MOTORI • BAR FOR ENGINES
SERIE - JOHNSON - EVINRUDE 60/175 HP

cod. kg

00918
433580* 0,715

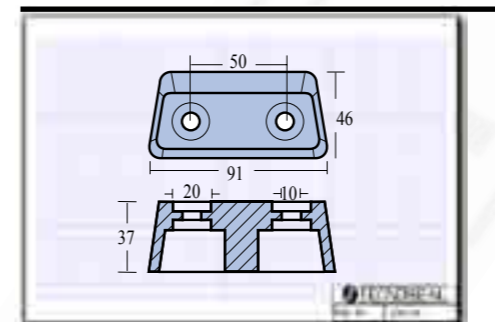

PLACCA PER MOTORI • SMALL BLOCK
SERIE - OMC COBRA

cod. kg

00919
986158* 0,605



* original code

* original code



PLACCA PER MOTORI • PLATE FOR ENGINES
SERIE - OMC COBRA 5700

cod. _____ kg

00920
987067* 0,980

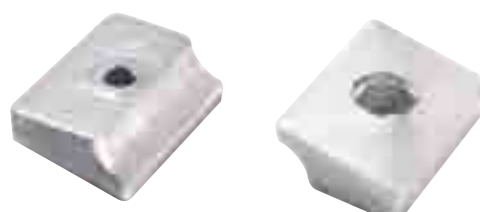
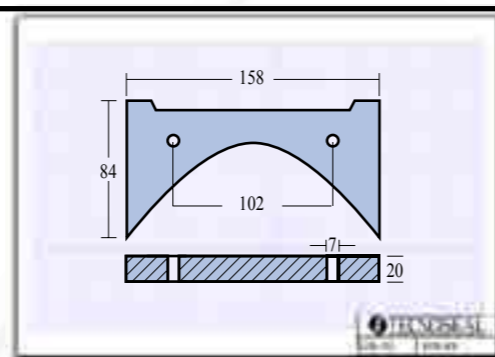

PLACCA PER MOTORI • PLATE FOR ENGINES
SERIE - JOHNSON 8-9,9-15 HP

cod. _____ kg

00921
338635* 0,055

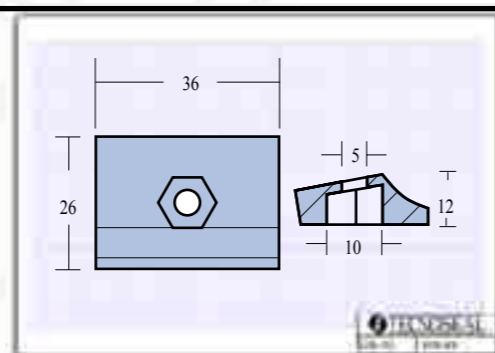

PLACCA PER MOTORI • BLOCK
SERIE - KING COBRA

cod. _____ kg

00922
3854130* 1,000

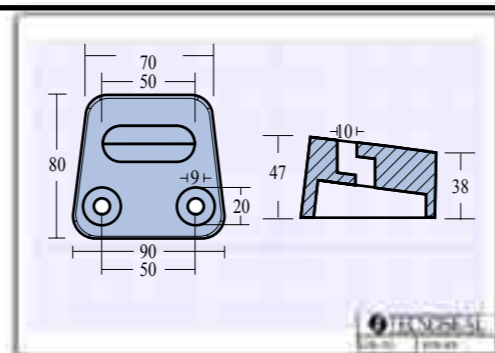

PLACCA PER MOTORI • HORSESHOE
SERIE - 225 HP

cod. _____ kg

00923
0,540

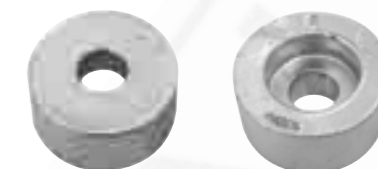
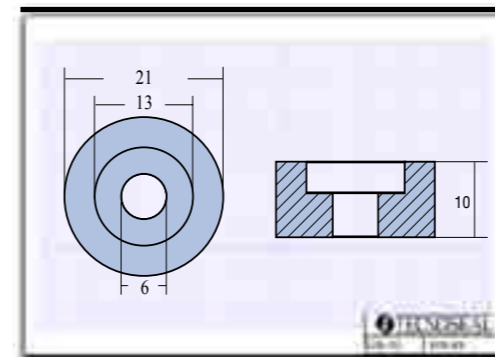
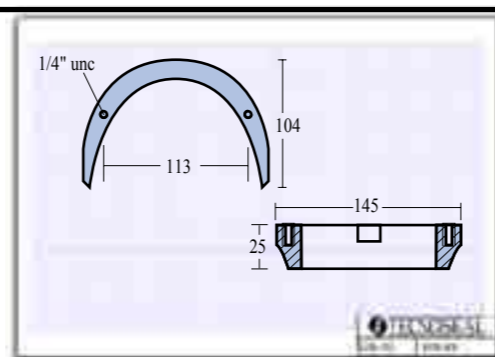

RONDELLA PER MOTORI • ENGINE WASHER

cod. _____ kg

00925
5031705* 0,020

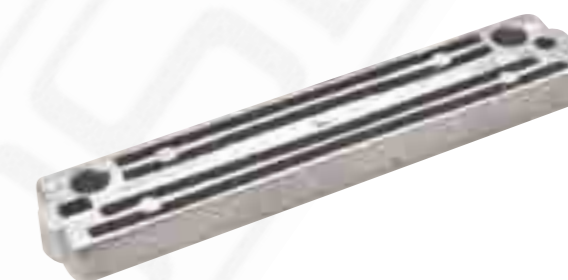
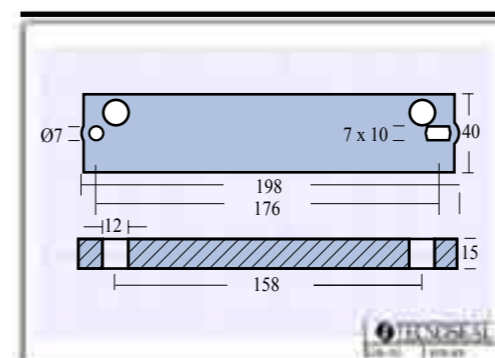

PIASTRA PER MOTORI EVINRUDE 40CV 4 TEMPI
PLATE FOR ENGINE

cod. _____ kg

00926
0,475



* original code

* original code

COLLARE PER MOTORI • COLLAR FOR ENGINES
SERIE - BMW MARK 1

cod. kg

01000		0,835
--------------	--	-------

PINNA LUNGA PER MOTORI • LONG SKEG FOR ENGINES
SERIE - BMW MARK 2

cod. kg

01001		3/8"unc	0,625
--------------	--	---------	-------

PINNA CORTA PER MOTORI • SHORT SKEG FOR ENGINES
SERIE - BMW MARK 1

cod. kg

01002		3/8"unc	0,335
--------------	--	---------	-------

PLACCA PER MOTORI • PLATE FOR ENGINES

cod. kg

01003		BMW 100 MARK 1	0,315
01004		BMW MARK 2	0,910

BARROTTO PER REFRIGERANTE • ROD FOR COOLER
SERIE - BMW

cod. l Ø Ø1 kg

01005		50	13	3/8"unc	0,050
--------------	--	----	----	---------	-------

COLLARE GORI • COLLAR GORI

cod. Ø elica kg

01020	3 BL		22"26"	1,345
--------------	------	--	--------	-------

OGIVA GORI • OGIVE GORI

cod. l Ø h Ø elica kg

01021	3BL		33	6	20	22"26"	0,090
01022	props		26	8	16	15"16,5"	0,035

OGIVA GORI • OGIVE GORI

cod. l Ø h Ø elica kg

01028	3BL		44	6	33	28"30"	0,260
--------------	-----	--	----	---	----	--------	-------

COLLARE GORI • COLLAR GORI

cod. Ø elica kg

01023	3 BL		28"30"	0,620
--------------	------	--	--------	-------

COLLARE GORI • COLLAR GORI

cod. Ø elica kg

01024	SD/3BL		18"20"	0,965
--------------	--------	--	--------	-------

COLLARE GORI • COLLAR GORI

cod. Ø elica kg

01025	SD/3P		15"16,5"	0,345
--------------	-------	--	----------	-------

* original code

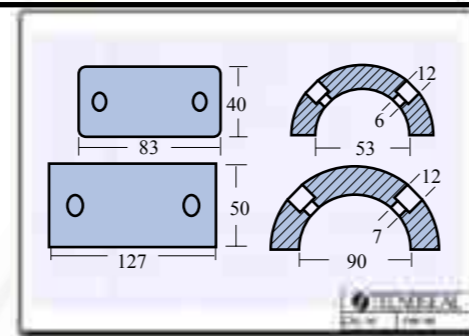

COLLARE GORI • COLLAR GORI

cod.	h	Ø elica	kg
01026 1553000000*	3BLS/prop	40	18"20" 0,845

cod.	h	Ø elica	kg
01027	3BLprop	50	28"30" 2,015

J Prop

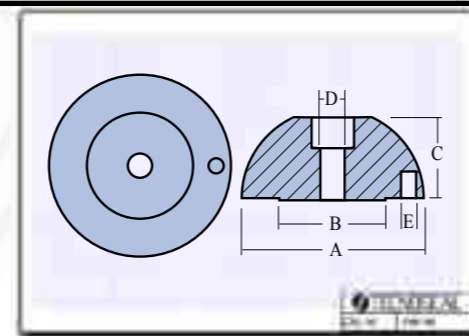
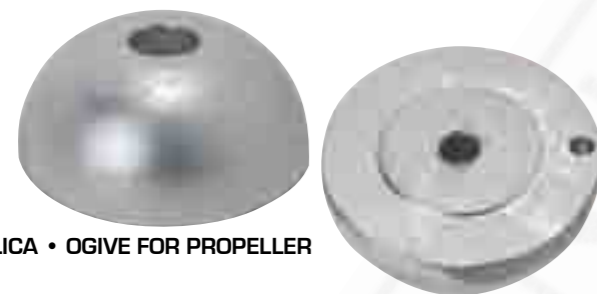

OGIVA PER ELICA • OGIVE FOR PROPELLER

cod.	A	B	C	D	E	kg
01030	60	34,5	26,0	8	5	0,360

cod.	A	B	C	D	E	kg
01032	90	49,5	37,0	10	6	1,050

Flex o Fold

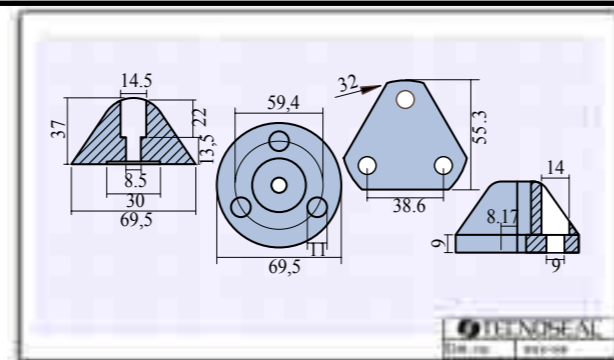
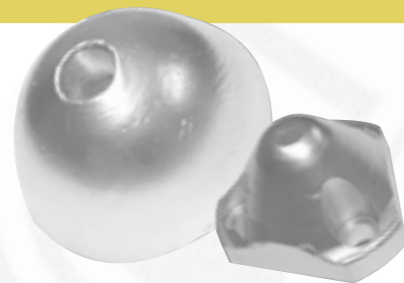

OGIVA TIPO FLEX O FOLD • NUT ANODE TYPE FLEX O FOLD

cod.	Ø	kg
01040	69,5	0,540

cod.	Ø	kg
01041	55,3	0,340

* original code

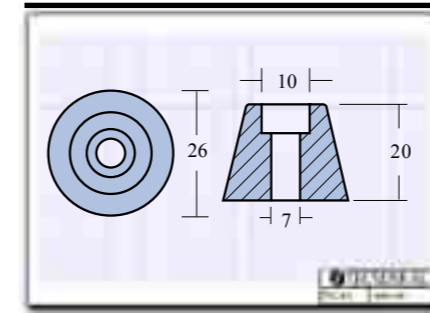

OGIVA TIPO SLEIPNER PER MOTORI SP30/40 4 HP
OGIVES SLEIPNER TYPE

cod.	kg
01050 61180*	0,045

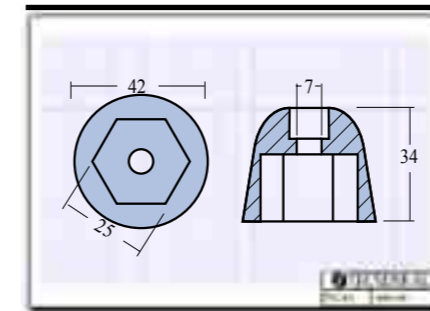

OGIVA PER BOW THRUST PER MOTORI SP125
OGIVE FOR BOW THRUST

cod.	kg
01051 101180*	0,160

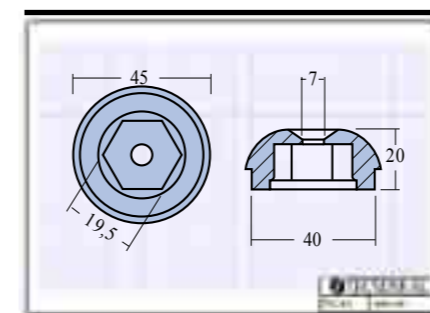

OGIVA PER BOW THRUST PER MOTORI SP 55/75/95
OGIVE FOR BOW THRUST

cod.	kg
01052 71190/51180*	0,120

Ogiva Variprop Variprop Ogive

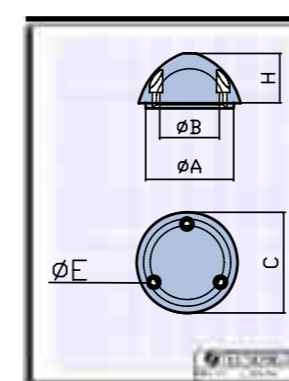

OGIVA VARIPROP
VARIPROP OGIVE

cod.	A	B	C	E	H
01070	59	44	67	6	38
01071	68	51	78	6	40

cod.	A	B	C	E	H
01072	84	60	90	6	54
01073	95	72	105	7	56

* original code

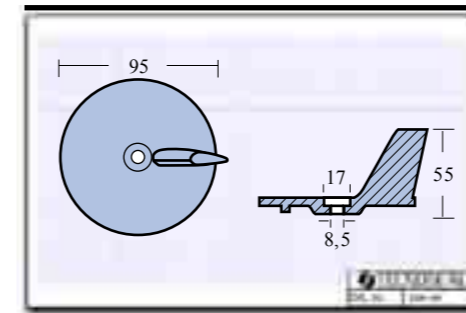

PINNA PER MOTORI • SKEG FOR ENGINES
SERIE - MARINER 10-50 HP YAMAHA 20-25-30 HP

cod. kg



0,205

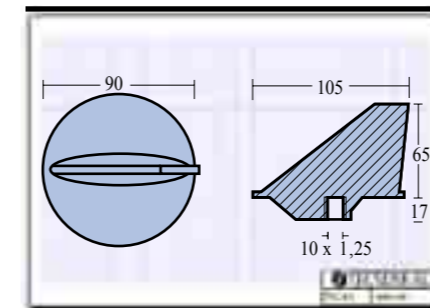

PINNA PER MOTORI • SKEG FOR ENGINES
SERIE - MARINER 40-60 HP 10X1,25 MARINER 40-60 HP 7/16" (DOPO IL 1991) YAMAHA 55 HP 10X1,25

cod. kg



0,455

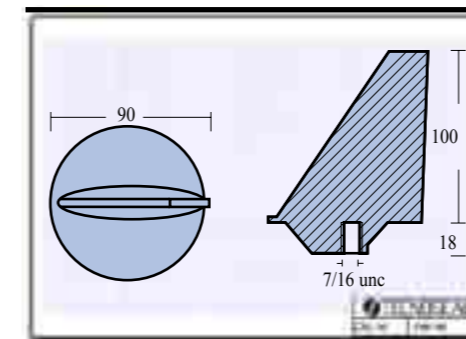

PINNA PER MOTORI • SKEG FOR ENGINES
SERIE - MARINER 90-140 HP

cod. kg



0,620

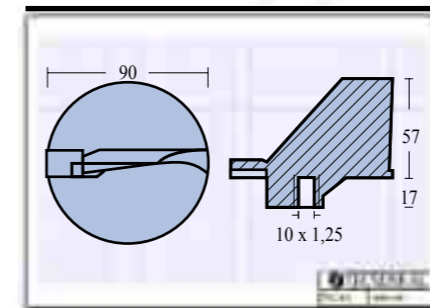

PINNA PER MOTORI • SKEG FOR ENGINES
SERIE - YAMAHA 115-225 HP (V4-V6)

cod. kg



0,385

* original code

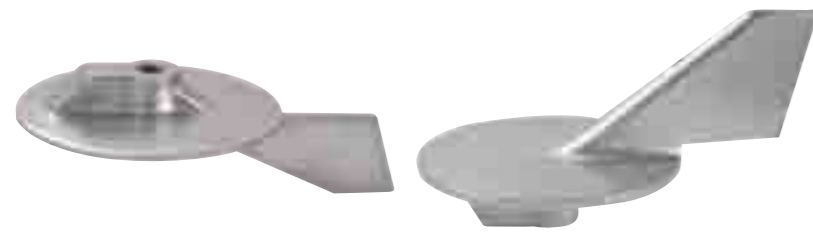

PINNA PER MOTORI • SKEG FOR ENGINES
SERIE - YAMAHA 60-90 HP

cod. _____ kg

01104 688-45371-02*  10x1,25 0,430

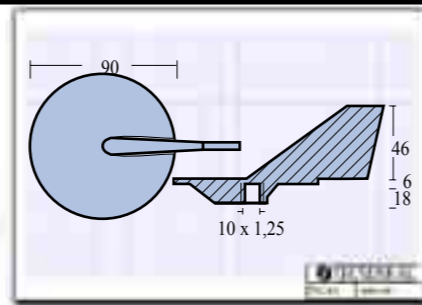

CUBO PER MOTORI • CUBE FOR ENGINES
SERIE - YAMAHA 115 225 HP

cod. _____ kg

01105 6E5-45251*  0,145

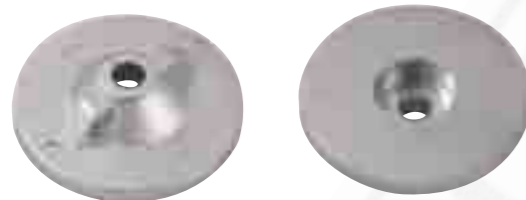
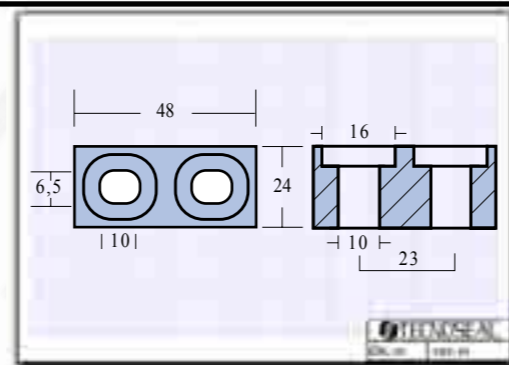

PIASTRINA PER MOTORI • PLATE FOR ENGINES
SERIE - YAMAHA 9,9 HP

cod. _____ kg

01106 6E8-4225100*  0,045

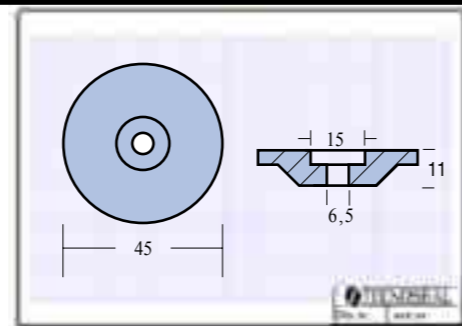

PIASTRINA PER MOTORI • PLATE FOR ENGINES
SERIE - MARINER 6 - 9,9 HP

cod. _____ kg

01107  0,030

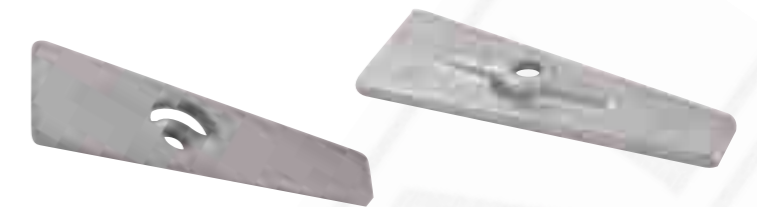
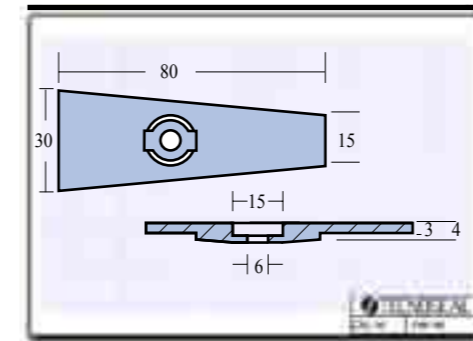
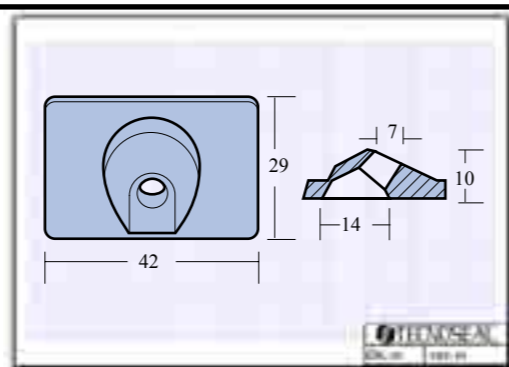

PIASTRINA PER MOTORI • PLATE FOR ENGINES
SERIE - SERIE YAMAHA 6-8 HP

cod. _____ kg

01108 6GN-DM652500*  0,040

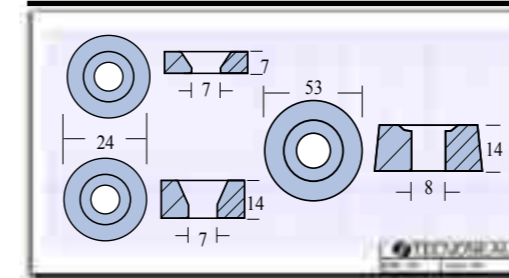



RONDELLE PER MOTORI • ENGINE WASHERS
SERIE - 2-115 HP

cod. _____ kg

01111  Mariner 40 HP
Yamaha 70-85 HP 0,210

cod. _____ kg

01109  Mariner 2-25 HP
Yamaha 2-25 HP 0,020

01110 688-45251-01*  Yamaha 60-85-115 HP 0,040

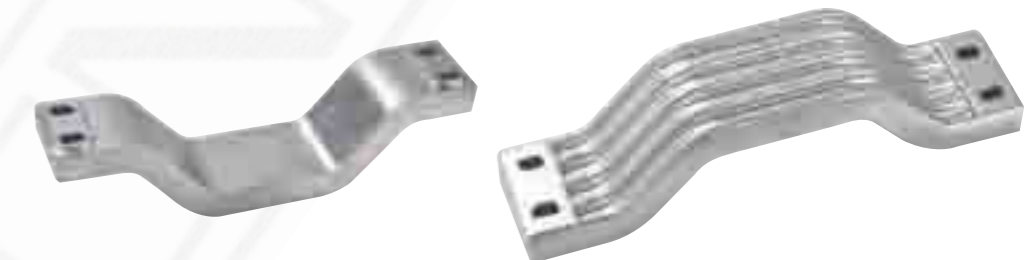
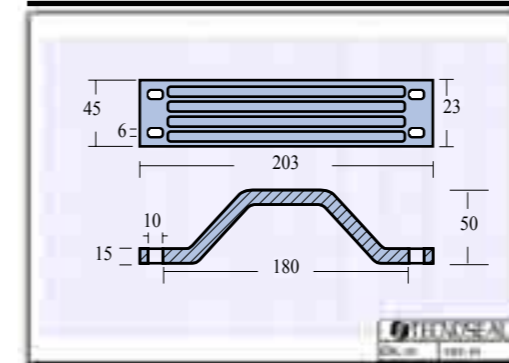

BARRA PER MOTORI • BAR FOR ENGINES
SERIE - YAMAHA MALTA 2/4, 3,5 HP - 2B/3 A/4 A/5C, 150/200HP

cod. _____ kg

01112 6G5-45251-02*  0,900

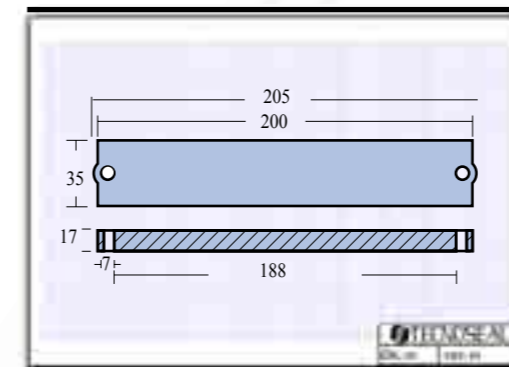

BARRA PER MOTORI • BAR FOR ENGINES
SERIE - YAMAHA 60-90 HP

cod. _____ kg

01113 6H1-45251-01*  0,545

* original code

* original code

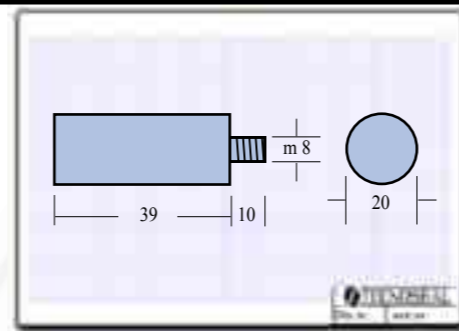

BARROTTO PER MOTORI • ROD FOR ENGINES
SERIE - YAMAHA

cod.	l	Ø1	Ø2	kg
01114	39	20	M8	0,090

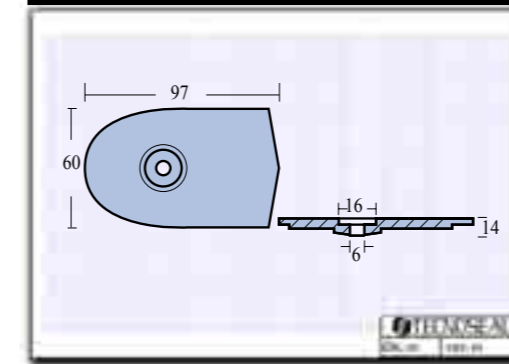

PIASTRINA PER MOTORI • PLATE FOR ENGINES
SERIE - YAMAHA 6C - 6D - 8C

cod.	kg
01118 6G1-45251-02*	0,175

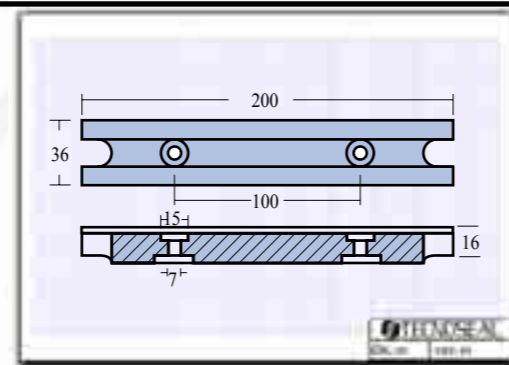

BARRA PER MOTORI • BAR FOR ENGINES
SERIE - YAMAHA TOP 700

cod.	kg
01115 6H1-45251-02*	0,460

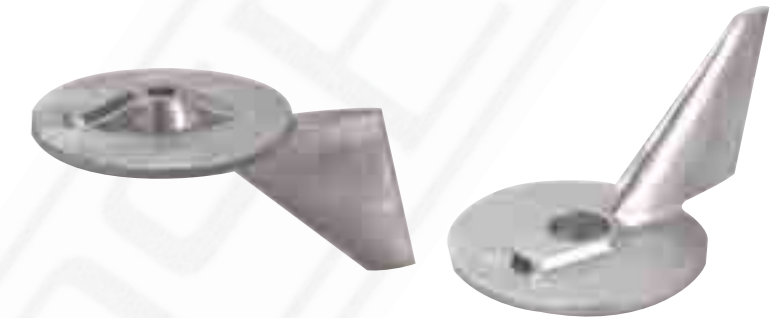
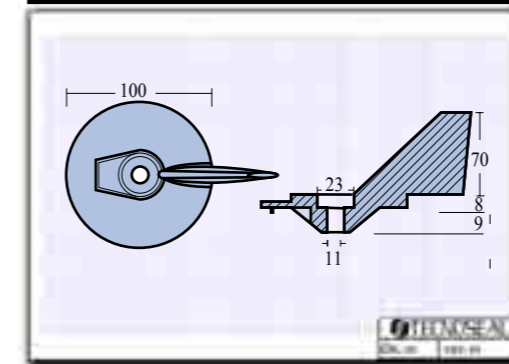

PINNA PER MOTORI • SKEG FOR ENGINES
SERIE - YAMAHA 130-205-230-260

cod.	kg
01119 6J9-45371-01* 6T5-45371-00*	0,580

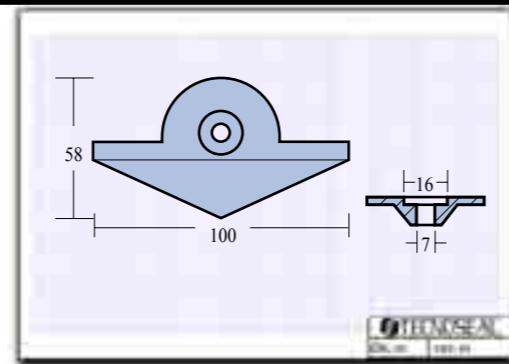
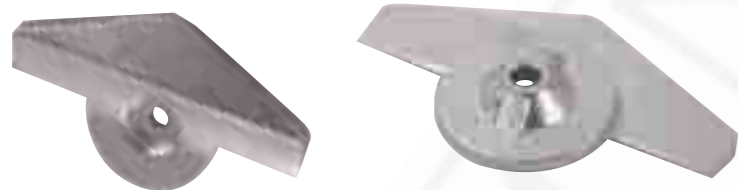

PLACCA PER MOTORI • PLATE FOR ENGINES
SERIE - YAMAHA 9,9 15 HP

cod.	kg
01116 6E8-45251*	0,140

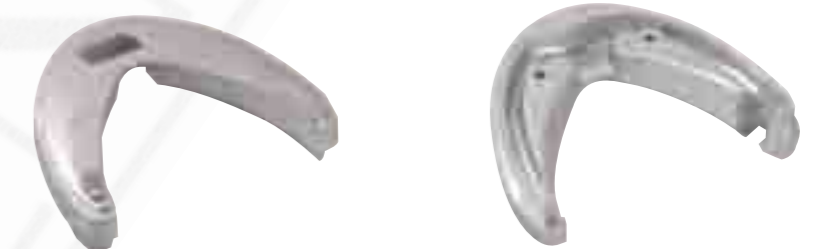
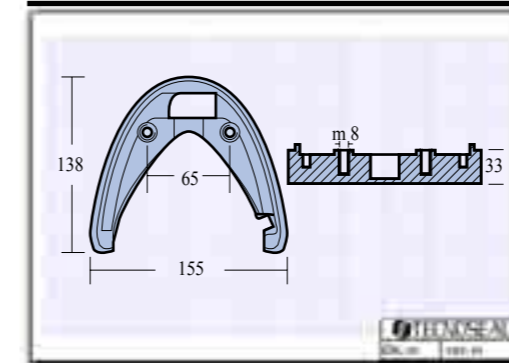

PLACCA PER MOTORI • HORSESHOE
SERIE - YAMAHA 130-205-230-260

cod.	kg
01120	0,765

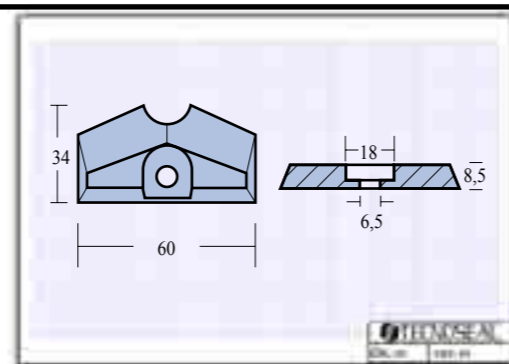
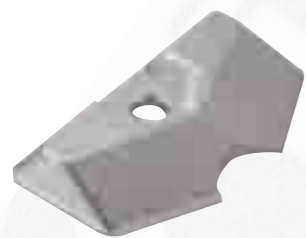

PIASTRINA PER MOTORI • PLATE FOR ENGINES
SERIE - YAMAHA MALTA 3,5 HP + 2B/3 A/4 A/5C

cod.	kg
01117 6L5-45251-03*	0,065

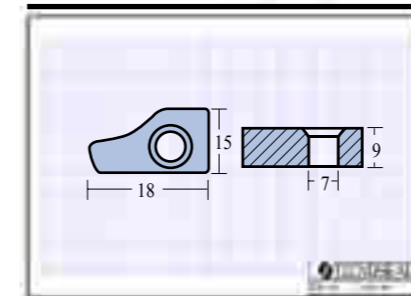

PIASTRINA PER MOTORI • PLATE FOR ENGINES
SERIE - MARINER H25-H8 20/2/3 YAMAHA W30-W8 25/2/3

cod.	kg
01121	0,020

* original code

* original code

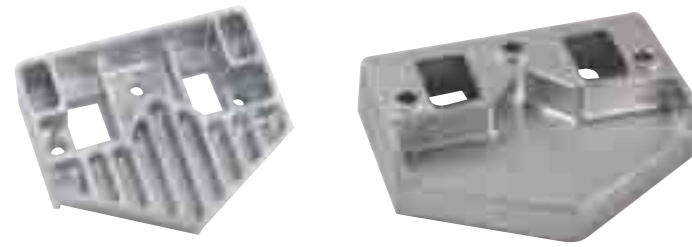

PLACCA PER MOTORI • BLOCK
SERIE - YAMAHA V8

cod. kg

01122 1,490

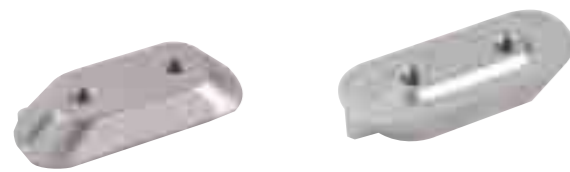
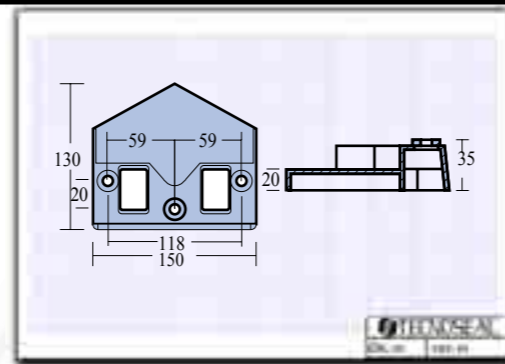

PIASTRINA PER MOTORI • PLATE FOR ENGINES
SERIE - YAMAHA 40 HP
A RICHIESTA CON FILETTO M6

cod. kg

01123 0,100

6E0-45251*
65W-45251-00*

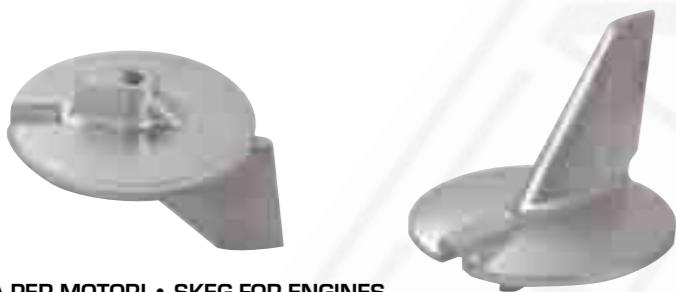
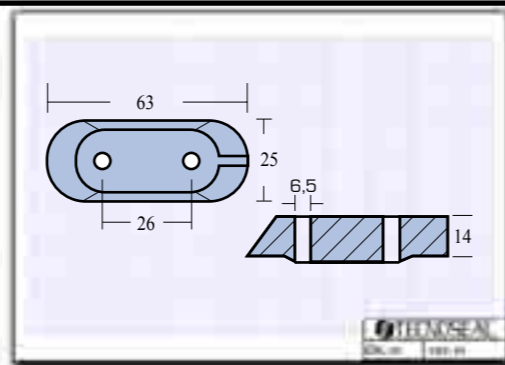

PINNA PER MOTORI • SKEG FOR ENGINES
SERIE - YAMAHA V8 - 250A 2TEMPI

cod. kg

01124 0,680

61A-45371-00*

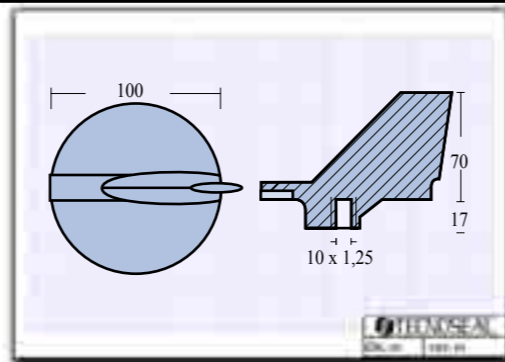

PLACCA PER MOTORI • PLATE FOR ENGINES
SERIE - 150/200 HP

cod. kg

01125 1,200

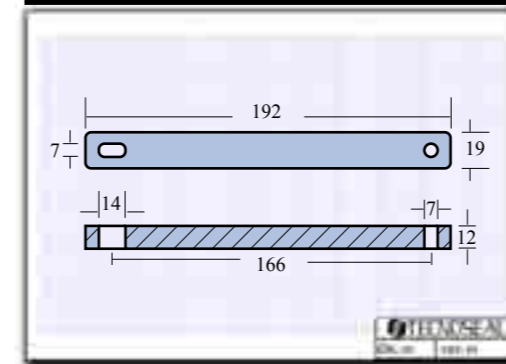
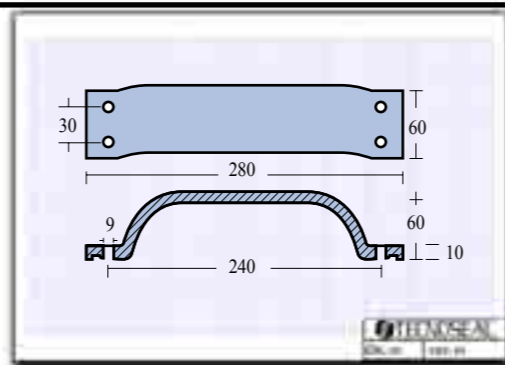

PIASTRA PER MOTORI • PLATE FOR ENGINES
SERIE - 30/40 HP

cod. kg

01126 0,285

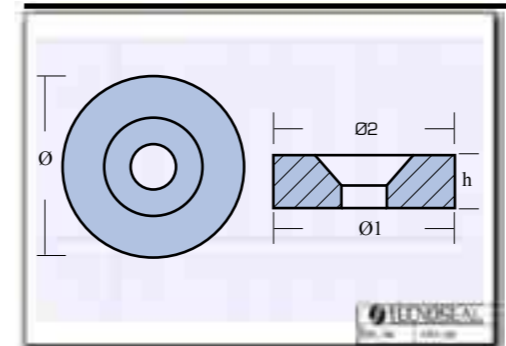

RONDELLE PER MOTORI • ENGINE WASHERS

cod. Ø h Ø1 Ø2 kg

01127 20 7 6,5 8 0,015



cod. Ø h Ø1 Ø2 kg

01128 24 6,5 6,5 8 0,020

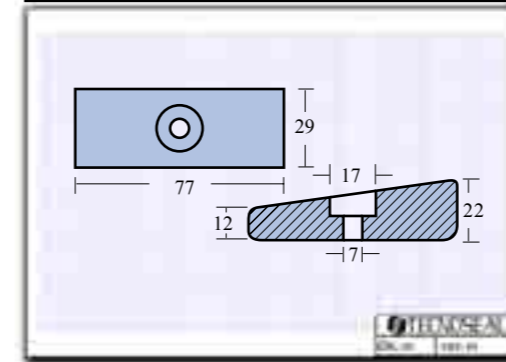

PIASTRINA PER MOTORI • PLATE FOR ENGINES
SERIE - 75 HP - XR6

cod. kg

01129 0,240

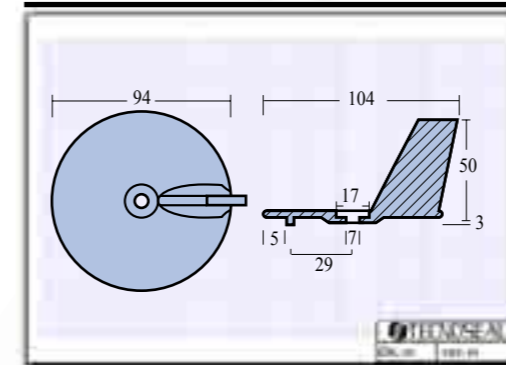

PINNA PER MOTORI • SKEG FOR ENGINES
SERIE - YAMAHA 25 - 30 HP

cod. kg

01130 0,270



* original code

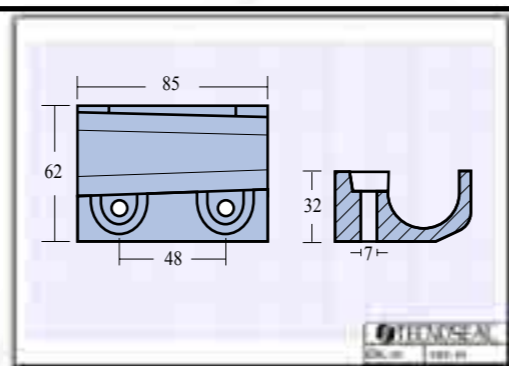
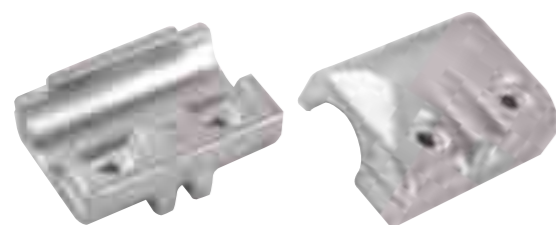

PLACCA I 48
PLATE H.C. 48

cod.	i	kg
01131	48	0,570

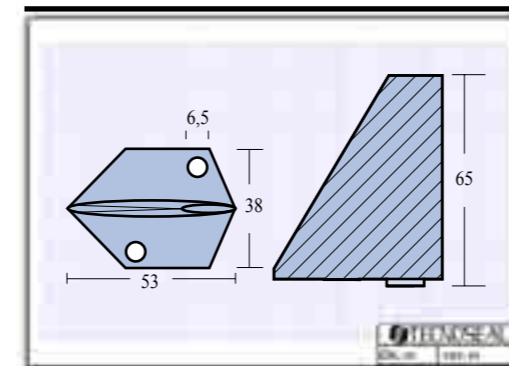

PINNA CON FORO • SKEG WITH HOLE
SERIE - 9.9 HP 4 T

cod.	kg
01136	0,085

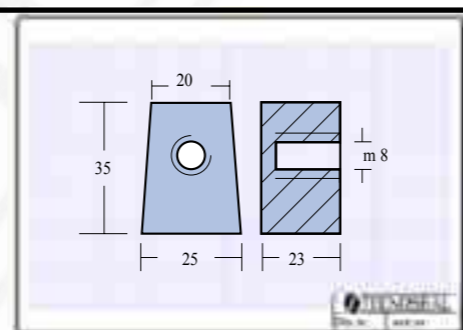

CUBO CON FORO • CUBE WITH HOLE

cod.	kg
01132	0,120

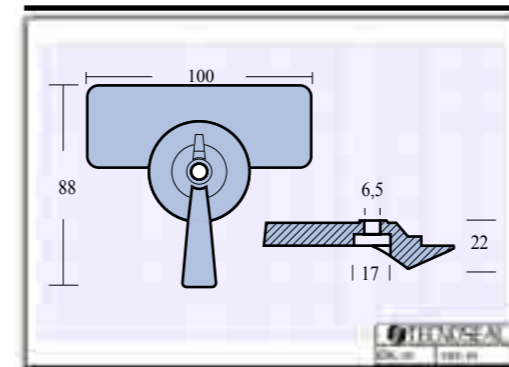

PLACCA CON FORO • PLATE WITH HOLE
SERIE - 9.9 HP

cod.	kg
01137	0,200

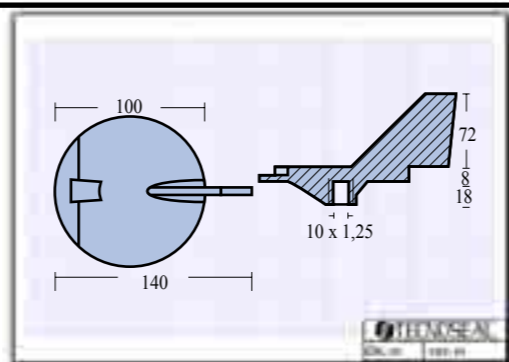

PINNA PER MOTORI • SKEG FOR ENGINES
SERIE - YAMAHA 150/220 HP

cod.	kg
01133 dx	0,625

cod.	kg
01134 sx	0,625

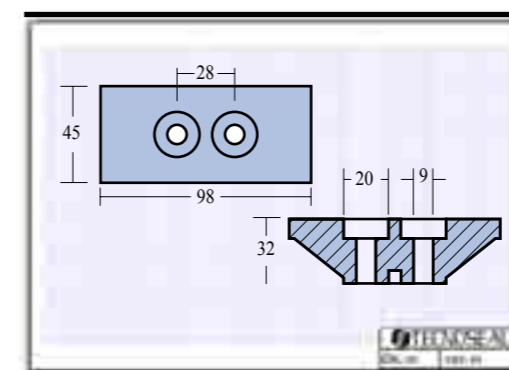

PLACCA CON FORI • PLATE WITH HOLES
SERIE - YAMAHA TD

cod.	kg
01138	0,275

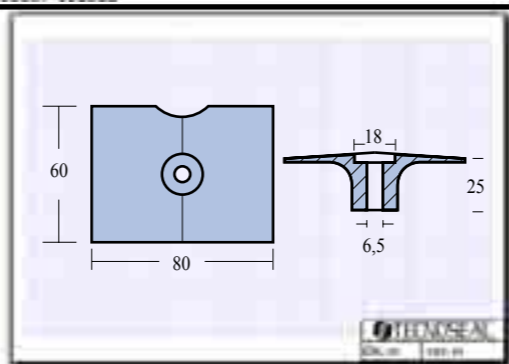

PLACCA CON FORO • PLATE WITH HOLE
SERIE - 4 T - 9,9/15F - 25 HP

cod.	kg
01135	0,265

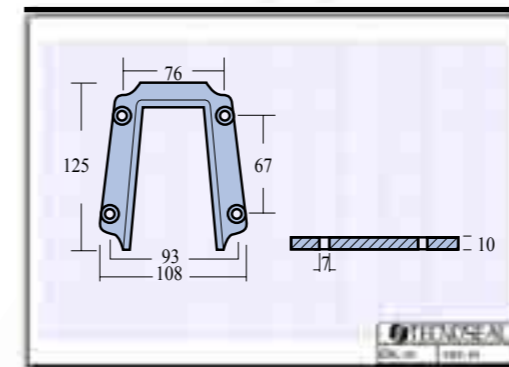

PLACCA CON FORI • PLATE WITH HOLES

cod.	kg
01139	0,350

* original code

* original code



PINNA PER MOTORI • ENGINE SKEG
SERIE - 80 - 100 HP - 4T

cod. _____ kg

01140
67F-45371-00* 0,400

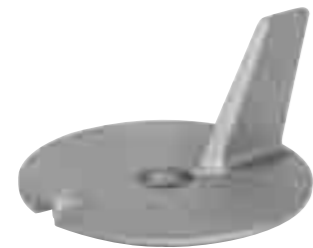
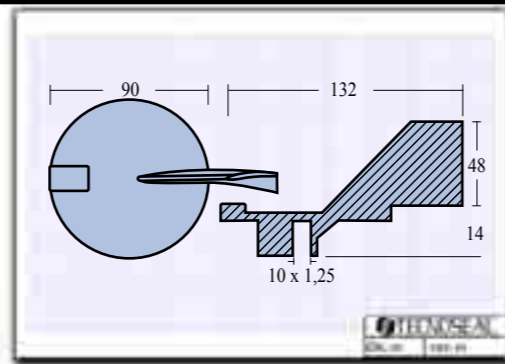

PINNE PER MOTORI YAMAHA F25-F40-F50
ENGINE SKEG FOR YAMAHA

cod. _____ kg

01141
67C-45371-00* 0,220

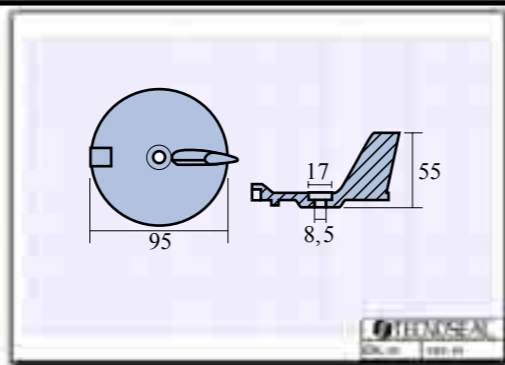

PIASTRA PER MOTORE • ENGINE PLATE ENGINE F8C-68T 2000
F8C - 68T '2000 (4T)

cod. _____ kg

01142
68T-45251-00* 0,100

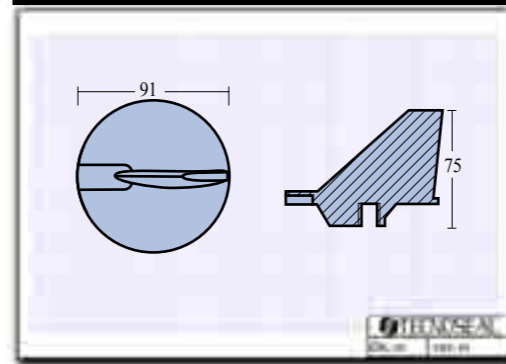
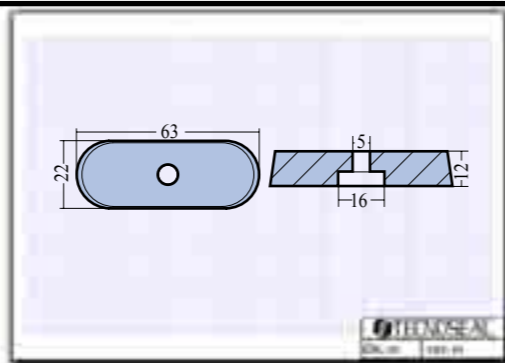

PINNA • SKEG ANODE

cod. _____ kg

01144
61K-45371-00* 0,405

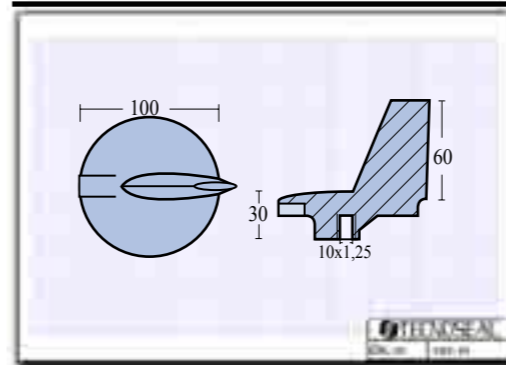

PINNA DIREZIONALE • SKEG ANODE

cod. _____ kg

01145
69L-45371-00* 0,655

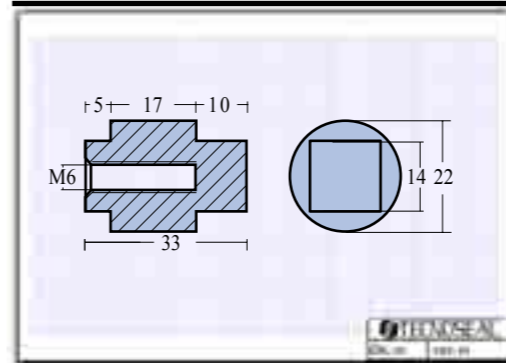

ANODO A CILINDRO PER MOTORI 80/100 HP
ENGINE ANODE 80/100 HP

cod. _____ kg

01146
67F-11325-00* 0,070

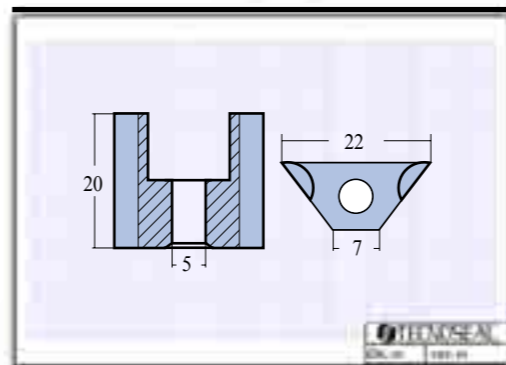

ANODI PER MOTORI 25/90 HP • ENGINE ANODE 25/90 HP

cod. _____ kg

01147
688-11325-00* 0,010

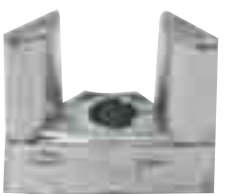

* original code

* original code



RONDELLA PER MOTORI 2,5/9,0 HP • ENGINE WASHER 2,5/9,0 HP

cod. _____ kg

01148
6G8-11325-00* 0,012

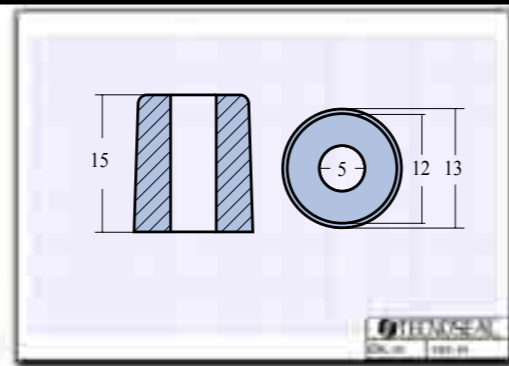

BARROTTO PER MOTORI 40/200 HP • ENGINE ROD 40/200 HP

cod. _____ kg

01149
62Y-11325-00* 0,015

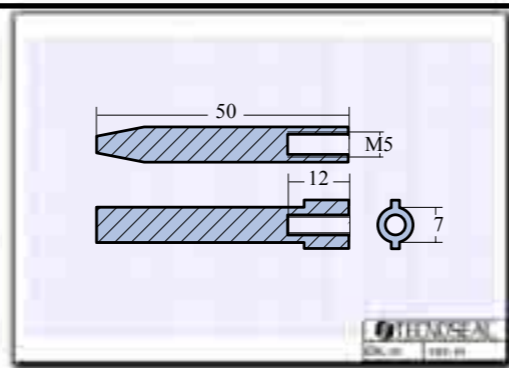

BARROTTO PER MOTORI 20/25 HP • ENGINE ROD 20/25 HP

cod. _____ kg

01150
6J8-11325-00* 0,015

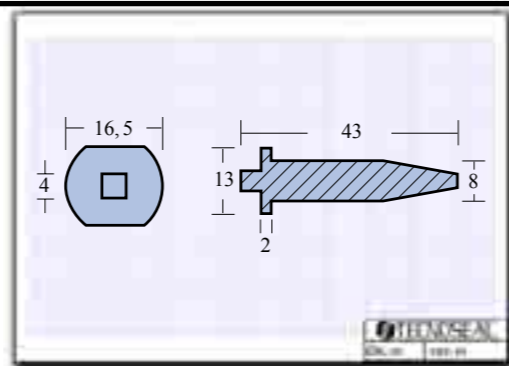

BARROTTO PER MOTORI 9,9 HP • ENGINE ROD 9,9 HP

cod. _____ kg

01151
66M-11325-00* 0,013

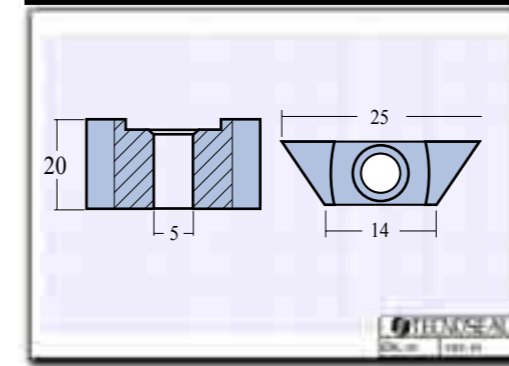
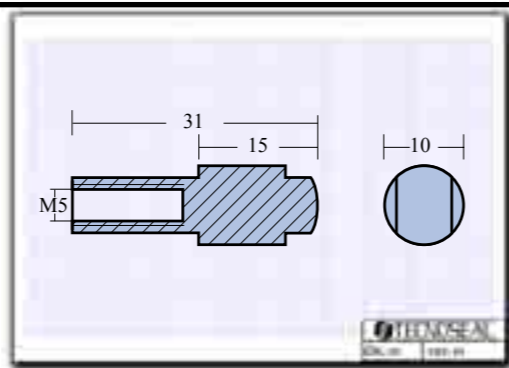

ANODO PER MOTORI 100/225 HP • ENGINE ANODE 100/225 HP

cod. _____ kg

01152
6E5-11325-00* 0,012

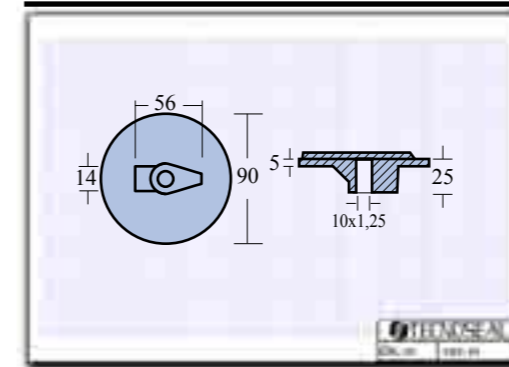
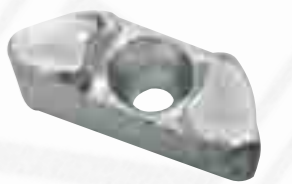

PLACCA PER MOTORI 60/225 HP • ENGINE PLATE 60/225 HP

cod. _____ kg

01153
6E5-45371-10* 0,337

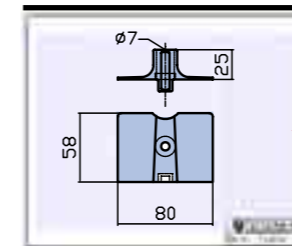

PIASTRINA ALLUMINIO PER MOTORE YAMAHA • LOWER UNIT ALUMINUM ANODE

cod. _____ kg

01154AL
6AH45251* 0,270

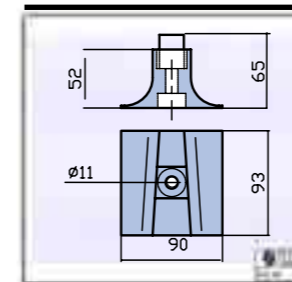
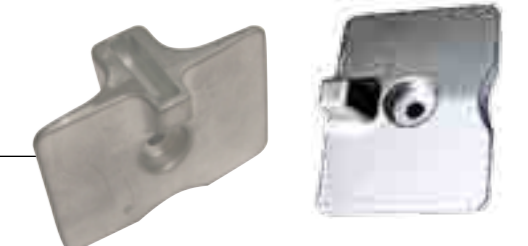

PIASTRINA ALLUMINIO PER MOTORE YAMAHA • LOWER UNIT ALUMINUM ANODE

cod. _____ kg

01155AL
6AW45373* 0,410

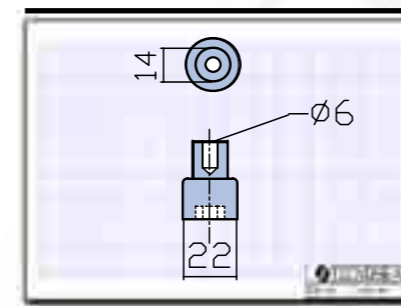

RONDELLA PER MOTORE YAMAHA CYLINDER HEAD ANODE

cod. _____ kg

01156
6BV11325* 0,025



* original code

* original code

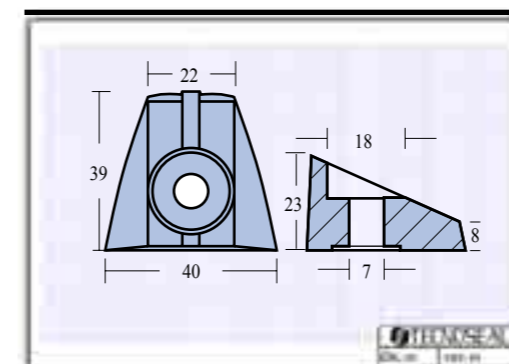

CONICO PER MOTORI • CONIC FOR ENGINES
SERIE - SUZUKI F.B.

cod. kg

01202
55320-98400*



0,095

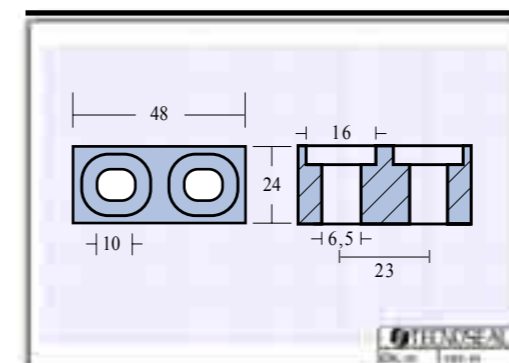

CUBO PER MOTORI • CUBE FOR ENGINES
SERIE - SUZUKI F.B.

cod. kg

01203
41810-87D00*



0,145

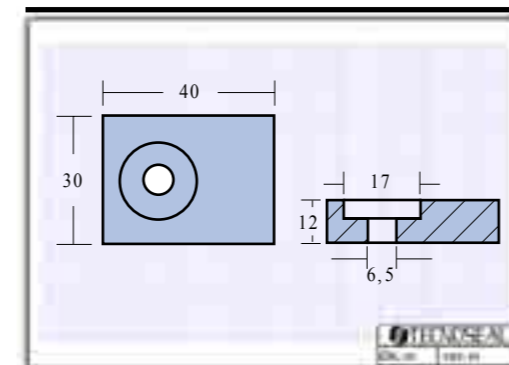

PIASTRINA PER MOTORI • PLATE FOR ENGINES
SERIE - SUZUKI 65-115 HP

cod. kg

01204
55320-953*



0,080



PINNA PER MOTORI • SKEG FOR ENGINES
SERIE - SUZUKI 20-25-30 HP

cod. kg

01200
55125-96310*



0,150

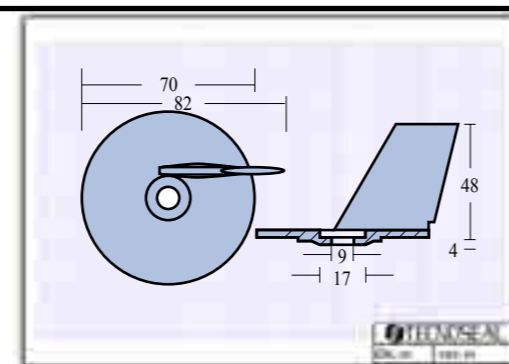

PINNA PER MOTORI • SKEG FOR ENGINES
SERIE - SUZUKI 55-65 HP

cod. kg

01201



0,160

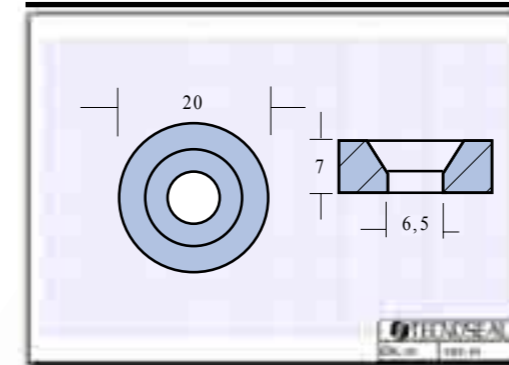
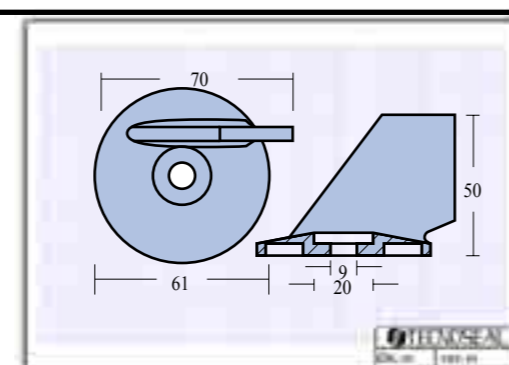

RONDELLA PER MOTORI • ENGINE WASHERS
SERIE - SUZUKI FB

cod. Ø kg

01205
11130-94600*



20 0,010



* original code

* original code



PIASTRINA PER MOTORI • PLATE FOR ENGINES
SERIE - SUZUKI 9,9-15 HP

cod. kg

01206
55321-93900* 0,050

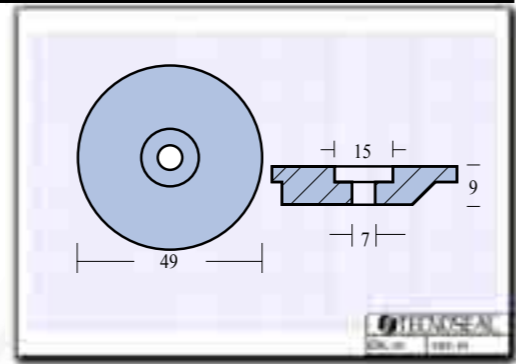

PINNA PER MOTORI • SKEG FOR ENGINES
SERIE - SUZUKI 75-85-90 HP

cod. kg

01207
5031536* 0,170

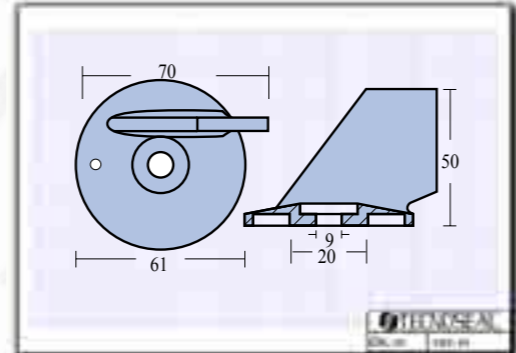

PIASTRINA PER MOTORI • PLATE FOR ENGINES
SERIE - SUZUKI 2-4-6-8 HP

cod. kg

01208
55300-95500* 0,080

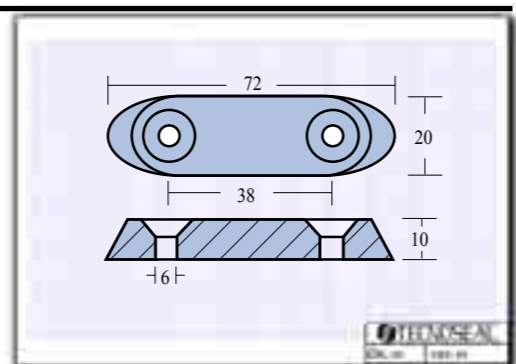

PINNA PER MOTORI • SKEG FOR ENGINES
SERIE - SUZUKI 115 HP

cod. kg

01209
0,325

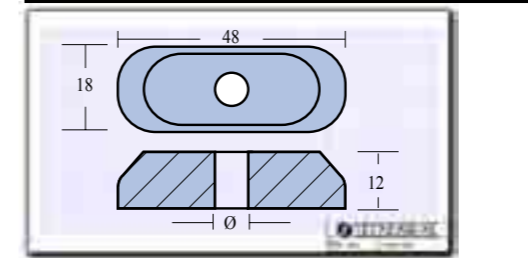
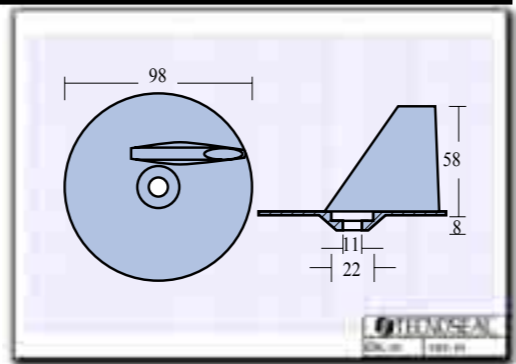

cod. Ø kg

01210/1
41811-98500* M6 0,050

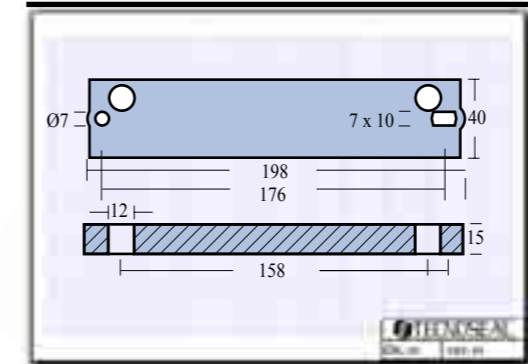
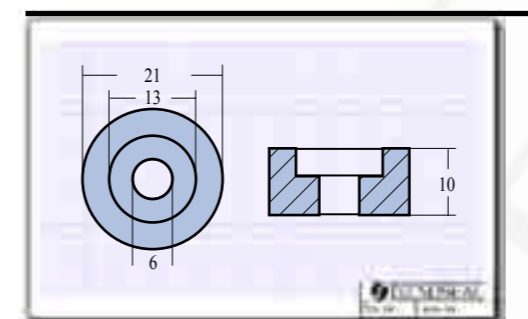
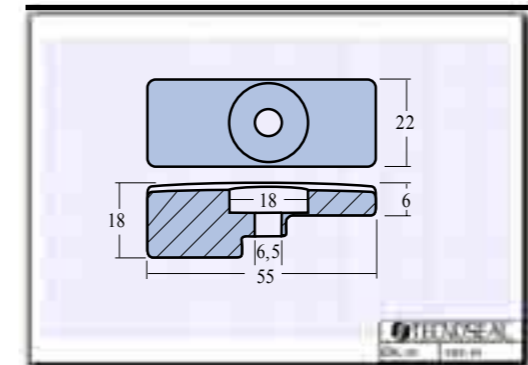
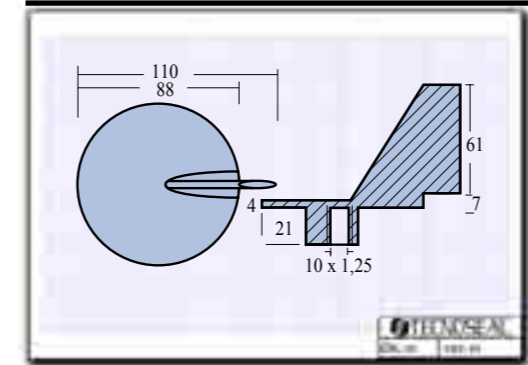

PIASTRINA PER MOTORI • PLATE FOR ENGINES
SERIE - SUZUKI 2 HP

cod. Ø kg

01210
55320-98400* 7 0,050

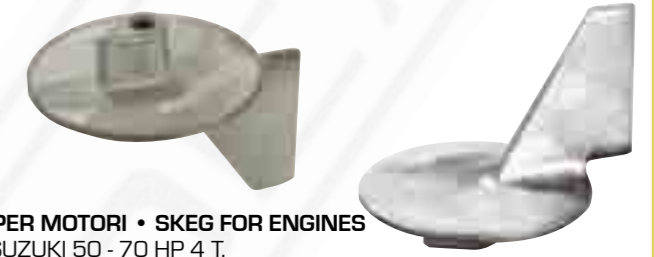

PINNA PER MOTORI • SKEG FOR ENGINES
SERIE - SUZUKI 50 - 70 HP 4 T.

cod. kg

01211
0,310



PIASTRINA PER PIEDE MOTORE
PLATE FOR ENGINE
SERIE - DF 90-115-140

cod. kg

01212
55321-90J01* 0,075



RONDELLA PER MOTORI
ENGINE WASHER

cod. kg

01213
5031705* 0,020

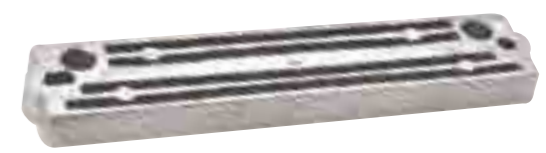

PIASTRA PER MOTORI • PLATE FOR ENGINES
70 - 90 - 115 - 140 - 150 CV

cod. kg

01214
55320-94900* 0,475

* original code

* original code

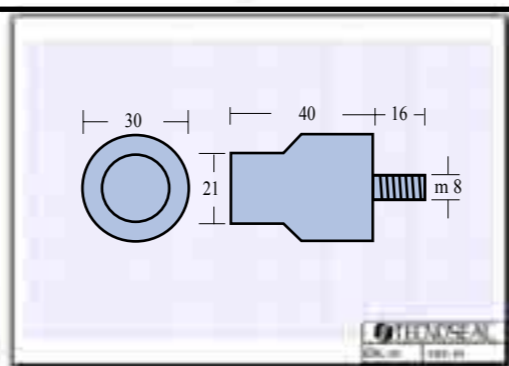

BARROTTO PER MOTORI • ROD FOR ENGINES
SERIE - YANMAR 8-10 HP

cod.	l	Ø1	Ø2	kg
------	---	----	----	----

01300	40	30	8 X 1,25	0,155
--------------	----	----	----------	-------

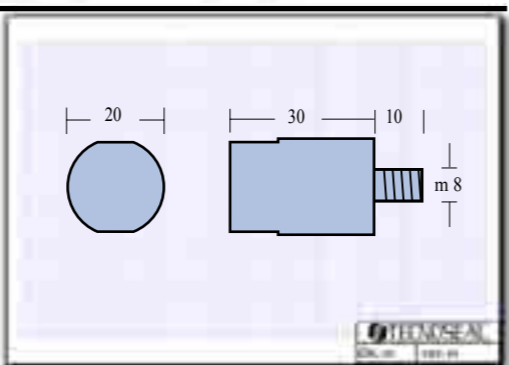

BARROTTO PER MOTORI • ROD FOR ENGINES
SERIE - YANMAR 8-12 HP

cod.	l	Ø1	Ø2	kg
------	---	----	----	----

01301	30	20	8X1,25	0,070
--------------	----	----	--------	-------

27210-200300*



RONDELLA PER MOTORI • ENGINE WASHER
SERIE - YANMAR 70-85 HP

cod.	kg
------	----

01302	53X15	0,210
--------------	-------	-------

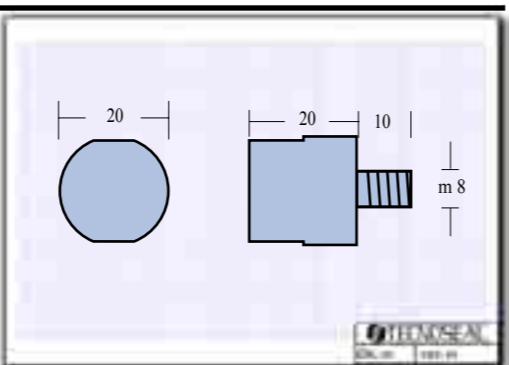
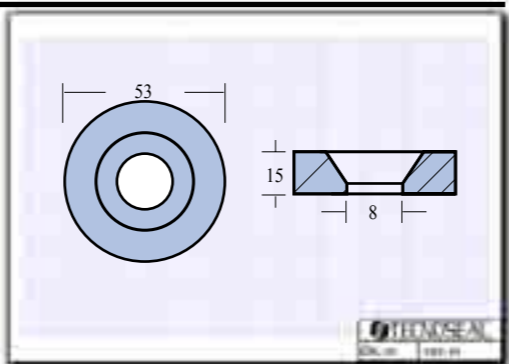

BARROTTO PER MOTORI • ROD FOR ENGINES
SERIE - YANMAR

cod.	l	Ø1	Ø2	kg
------	---	----	----	----

01303	20	20	8 X 1,25	0,045
--------------	----	----	----------	-------

27210-200200*



* original code

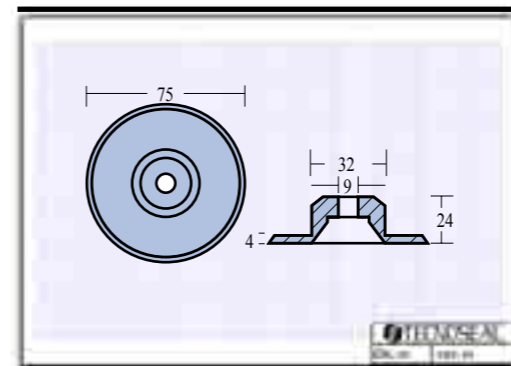

PLACCA PER MOTORI • PLATE FOR ENGINES
SERIE - YANMAR

cod.	kg
------	----

01304	0,190
--------------	-------

01304

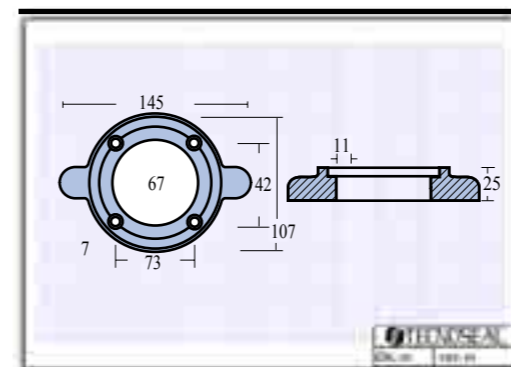

COLLARE PER MOTORI • COLLAR FOR ENGINES
SERIE - YANMAR

cod.	kg
------	----

01305	0,830
--------------	-------

01305

196420-02652*

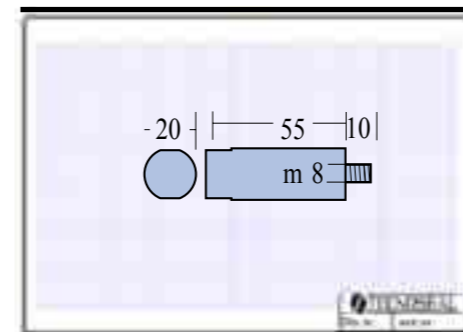
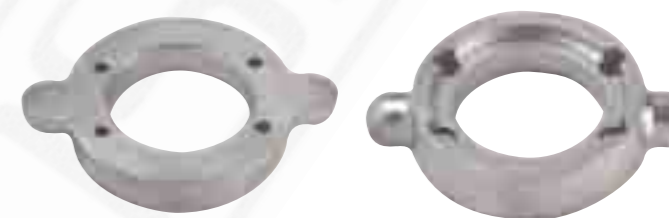

BARROTTO PER MOTORI • ROD FOR ENGINES
SERIE - YANMAR 8-12 HP

cod.	l	Ø1	Ø2	kg
------	---	----	----	----

01306	55	20	M 8	0,120
--------------	----	----	-----	-------

01306

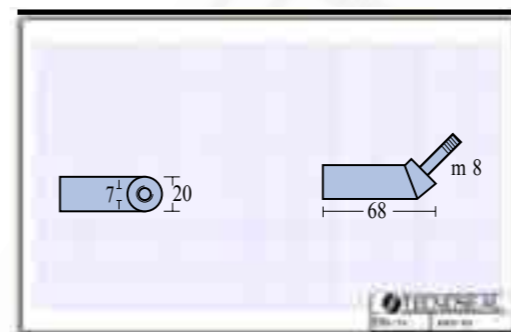

BARROTTO PER MOTORI • ROD FOR ENGINES
SERIE - YANMAR

cod.	l	Ø1	Ø2	kg
------	---	----	----	----

01308	68	20	M 8	0,145
--------------	----	----	-----	-------

01308



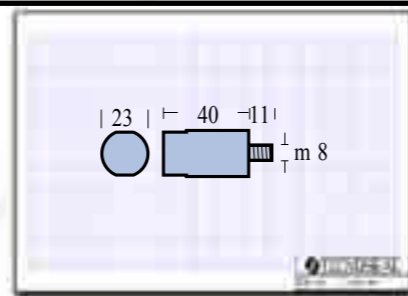

BARROTTO PER MOTORI • ROD FOR ENGINES
SERIE - YANMAR

cod.	l	Ø1	Ø2	kg
------	---	----	----	----

01309		40	23	M 8	0,090
--------------	--	----	----	-----	-------

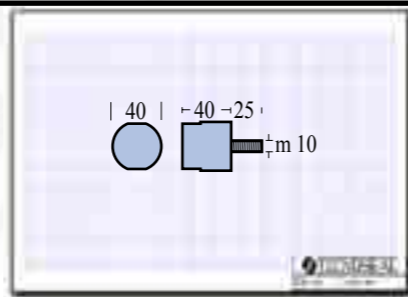
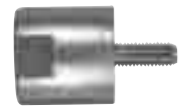

BARROTTO PER MOTORI • ROD FOR ENGINES

cod.	l	Ø1	Ø2	kg
------	---	----	----	----

01310		40	40	M 10	0,360
--------------	--	----	----	------	-------

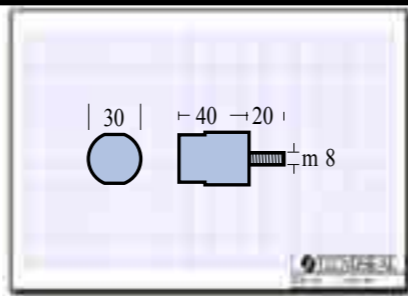

BARROTTO PER MOTORI • ROD FOR ENGINES

cod.	l	Ø1	Ø2	kg
------	---	----	----	----

01311		40	30	M 8	0,200
--------------	--	----	----	-----	-------

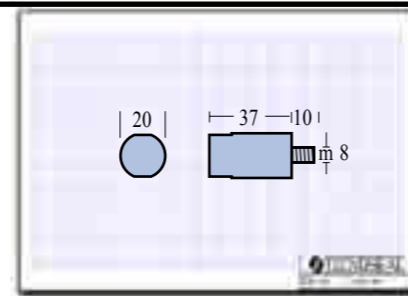

BARROTTO PER MOTORI • ROD FOR ENGINES

cod.	l	Ø1	Ø2	kg
------	---	----	----	----

01312		37	20	M 8	0,080
--------------	--	----	----	-----	-------

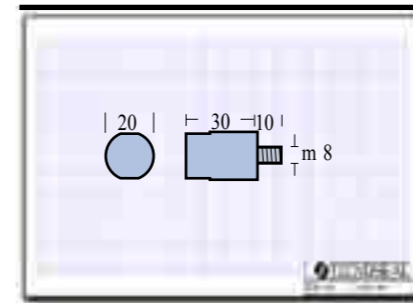

BARROTTO PER MOTORI • ROD FOR ENGINES

cod.	l	Ø1	Ø2	kg
------	---	----	----	----

01313		30	20	8X1,25	0,070
--------------	--	----	----	--------	-------

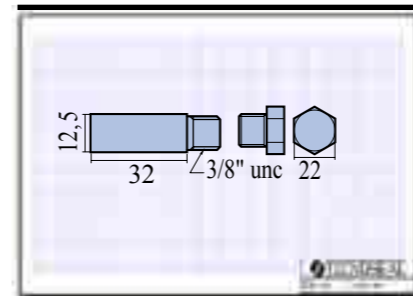

ANODO CON TAPPO PER MOTORI • ANODE WITH PLUG FOR ENGINES

cod.	kg
------	----

01316		0,030	SOLO ANODO ZINC ONLY
--------------	--	-------	-------------------------



cod.	kg
------	----

01316T		0,070	COMPLETO - COMPLETE
---------------	--	-------	---------------------

01316TP		0,040	SOLO TAPPO PLUG ONLY
----------------	--	-------	-------------------------

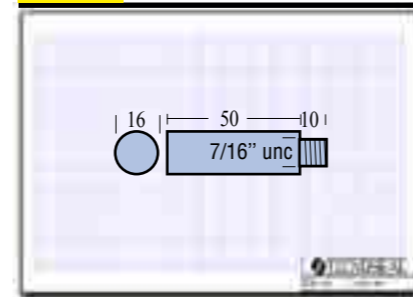

BARROTTO PER MOTORI • ROD FOR ENGINES

cod.	l	Ø1	Ø2	kg
------	---	----	----	----

01317		50	16	7/16"UNC	0,075
--------------	--	----	----	----------	-------

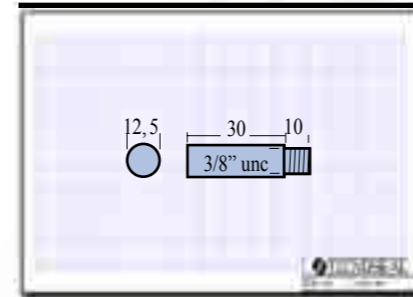

BARROTTO PER MOTORI • ROD FOR ENGINES

cod.	l	Ø1	Ø2	kg
------	---	----	----	----

01318		30	12,5	3/8"UNC	0,025
--------------	--	----	------	---------	-------



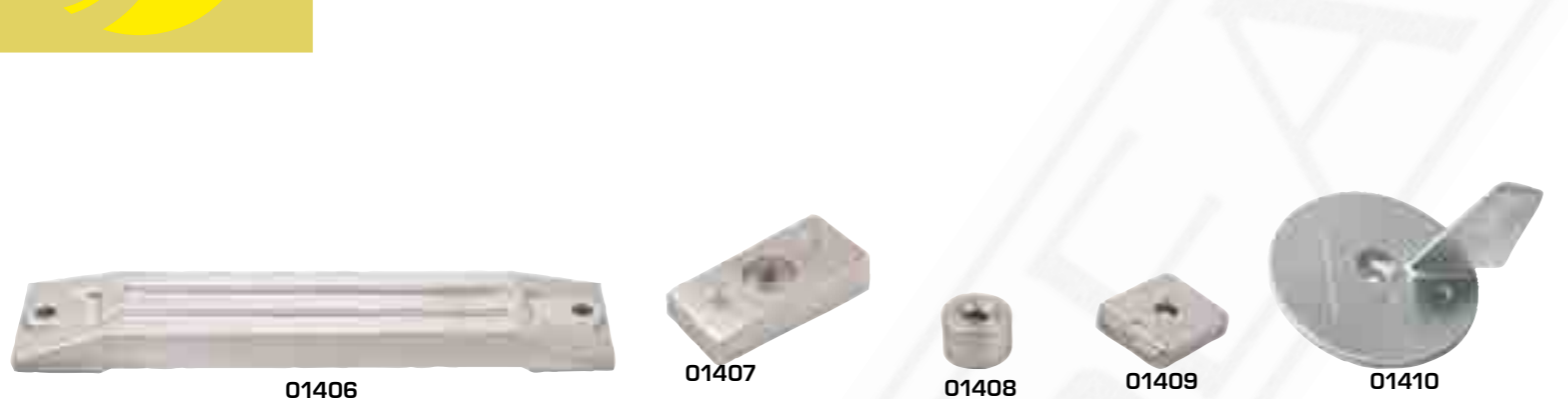

RONDELLA PER MOTORI • ENGINE WASHER
 SERIE - HONDA 8/20 HP
 cod. kg
01400 0,020
 41106-ZW-000*



PIASTRINA PER MOTORI • PLATE FOR ENGINES
 SERIE - HONDA FB 8/20 HP
 cod. kg
01401 0,075
 01402CORR366JR3*

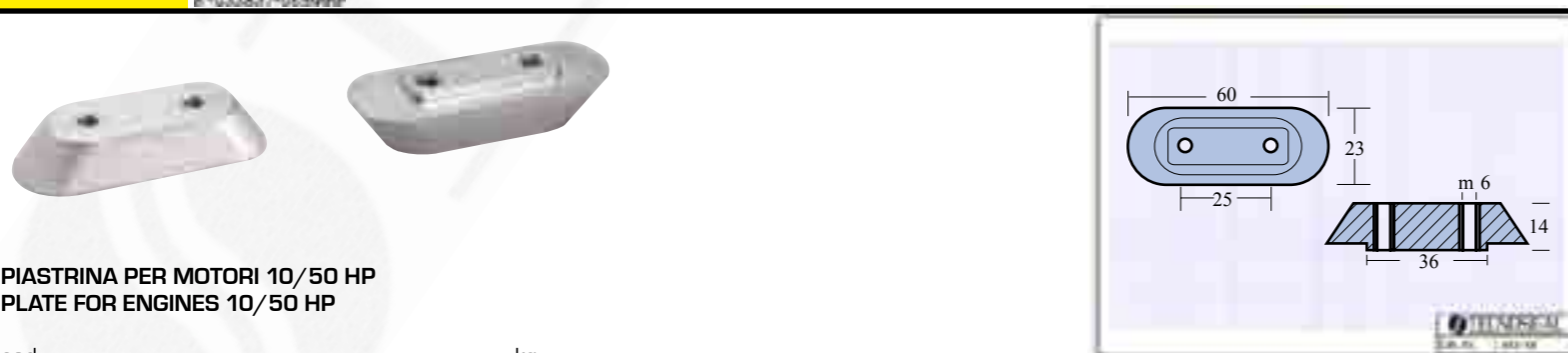

PIASTRINA PER MOTORI 10/50 HP
PLATE FOR ENGINES 10/50 HP
 cod. kg
01402 0,085
 41106-ZV4-650*
 41106-935-812*

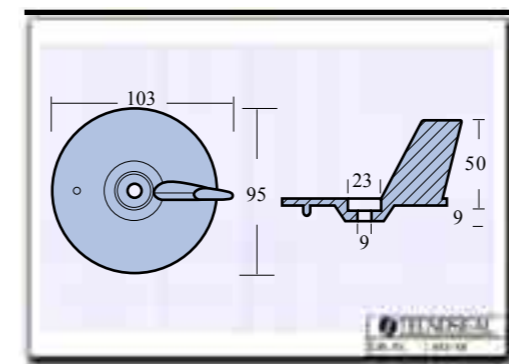

PINNA PER MOTORI • SKEG FOR ENGINES
 SERIE - 25-40-50 HP
 cod. kg
01403 0,280
 41107-ZV5-000*

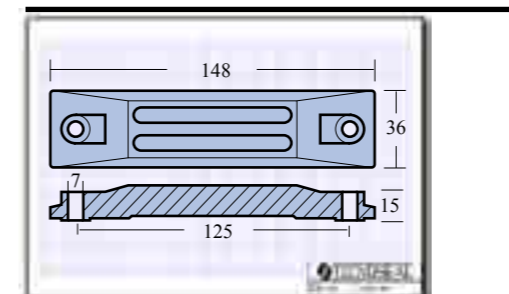

PLACCA PER MOTORI • PLATE FOR ENGINES
 SERIE - 40/50 HP
 cod. kg
01404 0,375
 06411-ZV5-000*

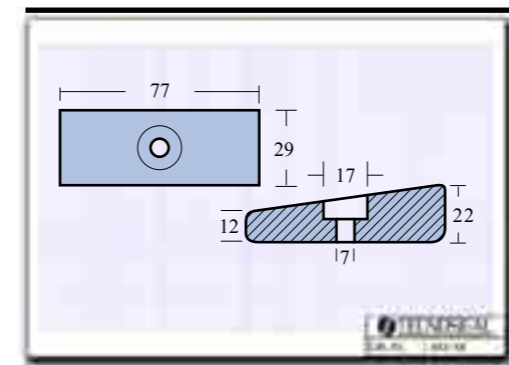

PIASTRINA PER MOTORI • PLATE FOR ENGINES
 SERIE - 75-130 HP
 cod. kg
01405 ZW1/W3 0,245
 41109-ZW1-003*

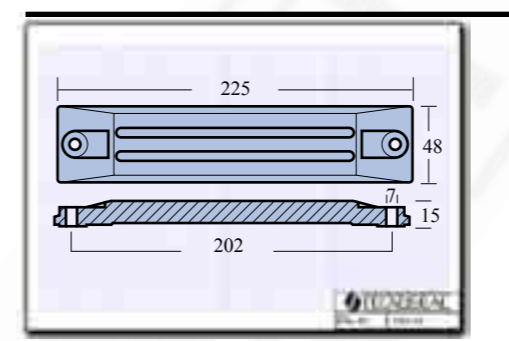

PLACCA PER MOTORI • PLATE FOR ENGINES
 SERIE - 75/130/225 HP
 cod. kg
01406 0,855
 06411-ZW1-000*

* original code

* original code

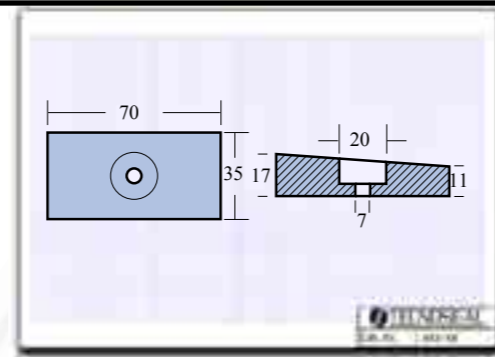

PIASTRINA PER MOTORI • PLATE FOR ENGINES
SERIE - HONDA 75-130-225 HP

cod. kg

01407 0,225

41109-ZW1-B00*

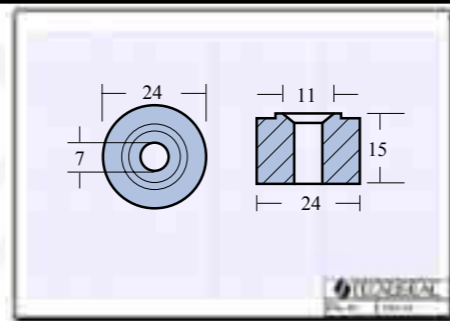

RONDELLA PER MOTORI • ENGINE WASHER
SERIE - HONDA

cod. Ø h kg

01408 24 15 0,040

12155-ZV5-000
12155-ZV4-A00*

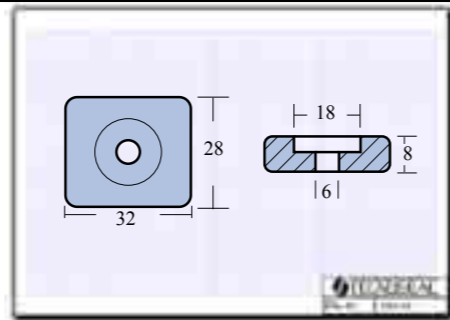
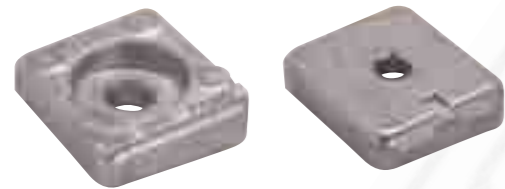

PIASTRINA PER MOTORI • PLATE FOR ENGINES
SERIE - HONDA 8-10-15 HP

cod. h kg

01409 32 X 28 10/8 0,050

41106-ZW9-000*

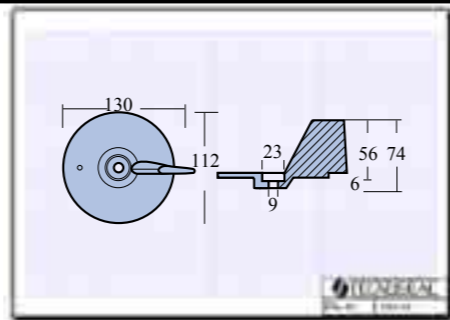

PINNA PER MOTORI • SKEG FOR ENGINES
SERIE - HONDA 8-10-15 HP

cod. kg

01410 0,550

41107-ZW1-B012A*

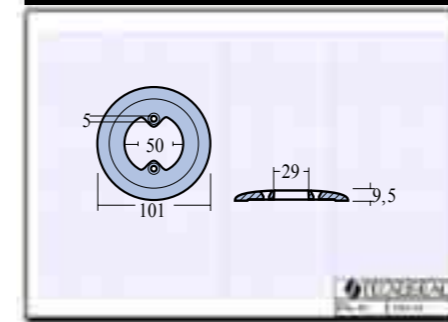

COLLARE • COLLAR
SERIE - BOILER

cod. Ø Ø1 i kg

01450 101 5 42 0,240

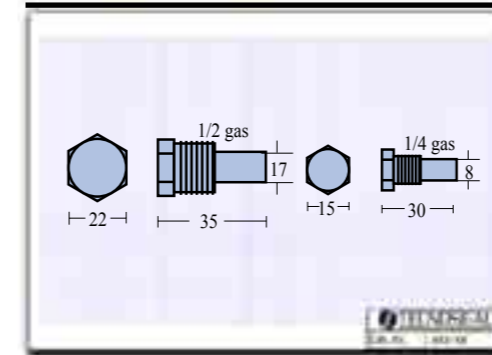

ANODI CON TAPPO • ANODES WITH PLUG
SERIE - BOILER

cod. Ø kg

01451 1/2" GAS CONICO 0,070



cod. Ø kg

01452 1/4" GAS CONICO 0,025

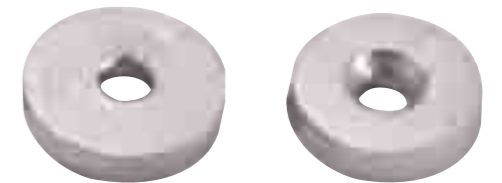

RONDELLA PER MOTORI • ENGINE WASHERS
SERIE - PIAGGIO

cod. kg

01500 0,030



* original code

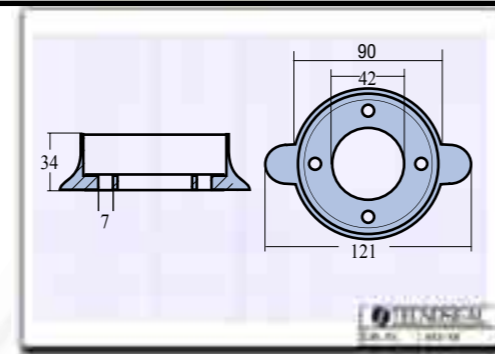

COLLARE PIEDINO MOTORE SAILDRIVE SLDM
SAILDRIVE ANODE FOR ENGINE SLDM

cod. kg

01550
1301339* 0,600

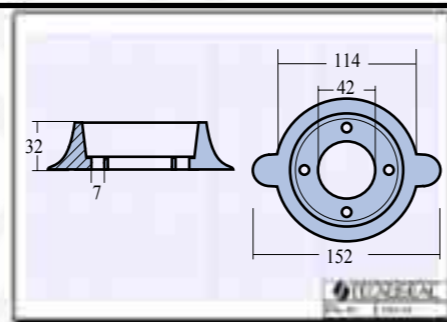

COLLARE PIEDINO MOTORE SAILDRIVE SLDM
SAILDRIVE ANODE FOR ENGINE SLDM

cod. kg

01551
1301350* 1,110

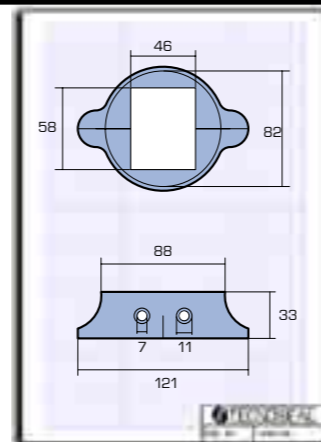
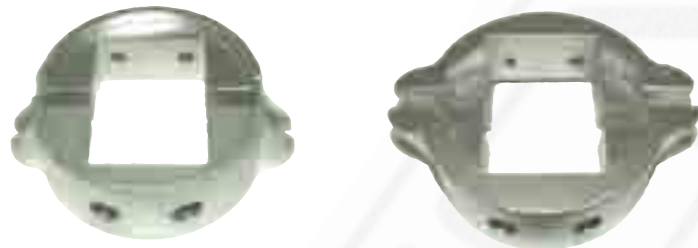

COLLARE PER MOTORE • SAILDRIVE ANODE FOR ENGINE

cod. kg

01552
9135033* 0,700

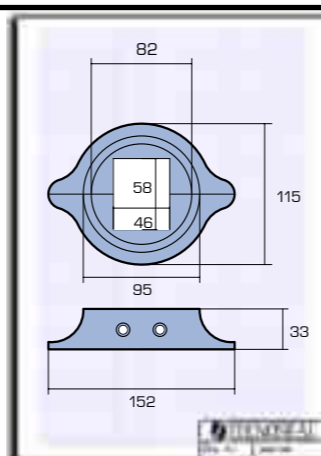
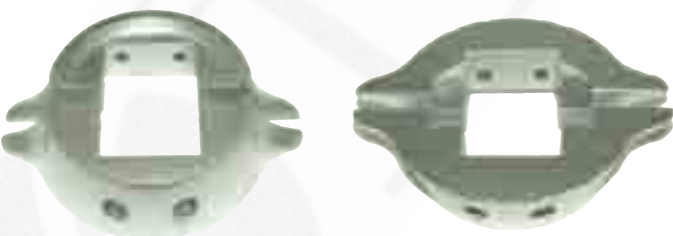

COLLARE PER MOTORE • SAILDRIVE ANODE FOR ENGINE

cod. kg

01553
9135034* 1,140

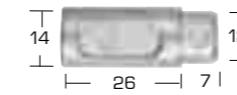

ANODO SCAMBIATORE

cod. kg

02350 0,032



TAPPO ESAG.

cod. kg

02350 TP 0,045 SOLO TAPPO

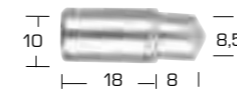

ANODO SCAMBIATORE

cod. kg

02351
0090802150* 0,015



TAPPO ESAG.

cod. kg

02351 TP 0,015 SOLO TAPPO

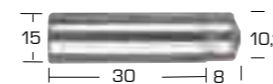

ANODO SCAMBIATORE A PRESSIONE ENGINE 2204MT - JMT

cod. kg

02353
090802840* 0,037



TAPPO ESAG. 24 FILETTO 18X1,5''

cod. esag. Fil.

02353 TP 24 18X1,5 SOLO TAPPO

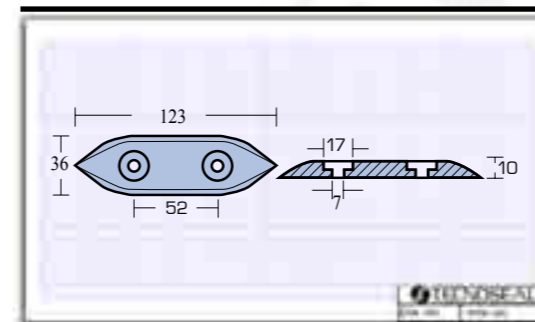

Chrysler

PIASTRINA PER MOTORI • PLATE FOR ENGINES
SERIE - CHRYSLER

cod. i kg l a h Ø1 Ø2

01600 52 0,185 123 36 10 7 17

* original code

* original code

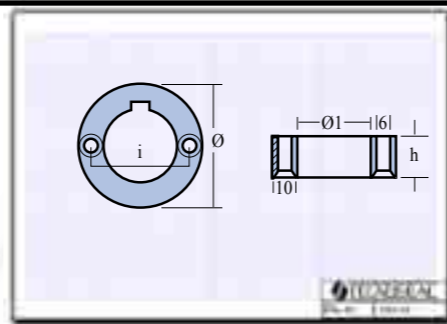

BOCCOLA PER ASSE • BUSH FOR SHAFT

cod.	Ø	Ø1	i	h	kg
01700	47	27	37	12	0,090
01701	52	28	39	14	0,140

cod.	Ø	Ø1	i	h	kg
01702	55	32	43	18	0,180

Renault Marine C.

BARROTTO PER REFRIGERANTE • ROD FOR COOLER
SERIE - RENAULT

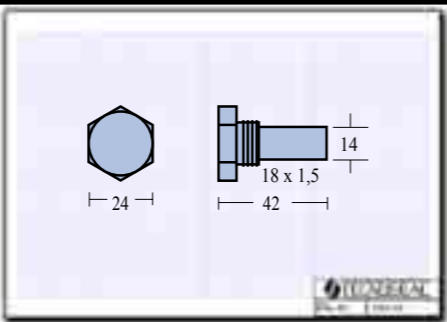
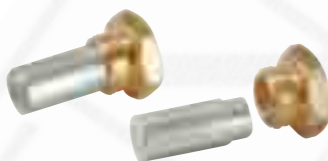

cod.	Fil.	kg
01800	18X1,5	0,070

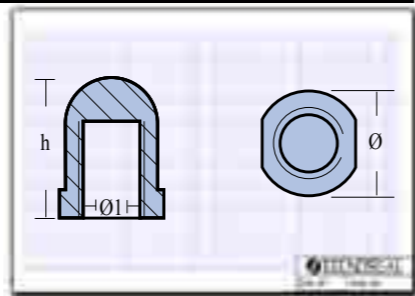
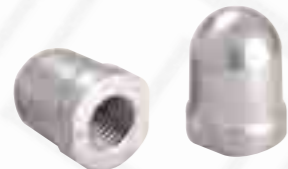

DADO PER ASSE • NUT FOR SHAFT

cod.	Ø asse	Ø	h	Ø1	kg
01801	22-25	27	35	16 X 2	0,075
01802	28-34	35	47	20 X 2,5	0,145

cod.	Ø asse	Ø	h	Ø1	kg
01803	40	40	48	28 X 2,5	0,230

PIASTRINA PER MOTORI • PLATE FOR ENGINES

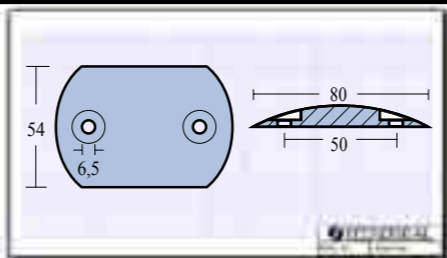
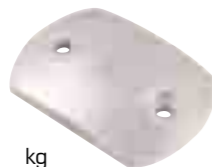

cod.	i	kg
01804	80 X 54	50

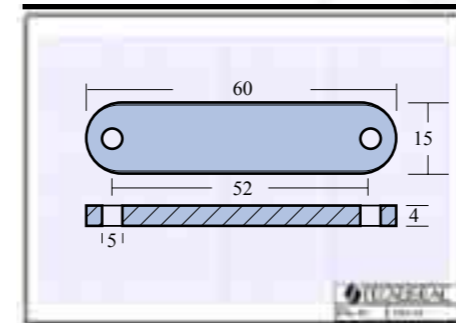

PIASTRINA PER MOTORI • PLATE FOR ENGINES
SERIE - PIATTA FB

cod.	kg
01900 9005655*	60X15X4

* original code



PIASTRINA PER MOTORI • PLATE FOR ENGINES
SERIE - CURVA FB

cod. kg

01901 57X15X4 0,025
9005660*

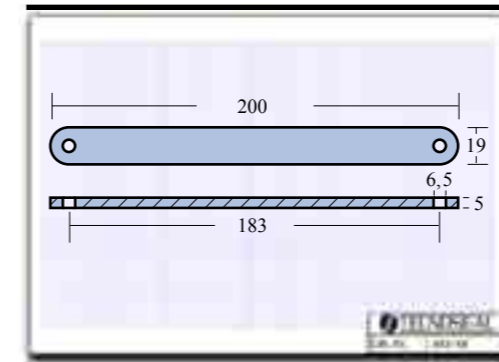
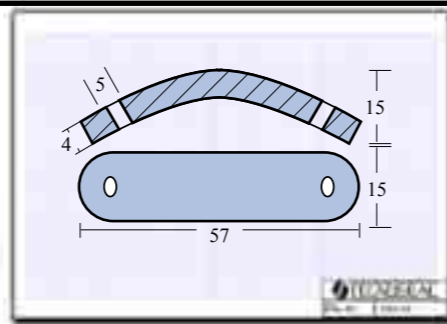

BARRA PER MOTORI • BAR FOR ENGINES
SERIE - LUNGA

cod. kg

01905 200X19X5 0,135



PINNA PER MOTORI • SKEG FOR ENGINES
SERIE - 6-8-9,9-15 HP

cod. kg

01902 0,100
2500010*

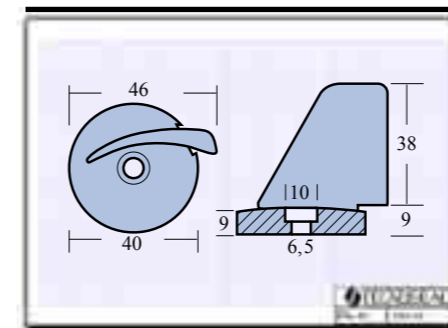
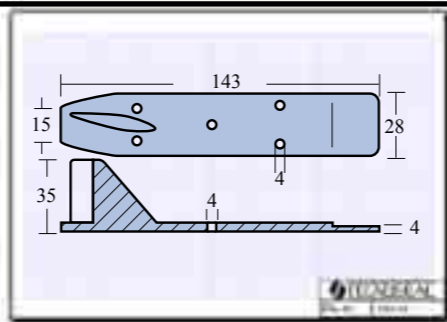

PINNA PER MOTORI • SKEG FOR ENGINES
SERIE - 25-40 HP

cod. kg

01906 0,070
2500065*



PINNA PER MOTORI • SKEG FOR ENGINES
SERIE - BEST 800 - S1000

cod. kg

01903 0,200
2500050*

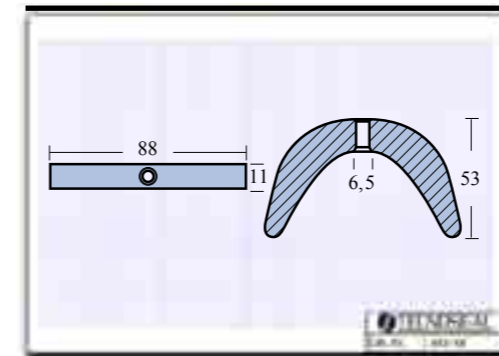
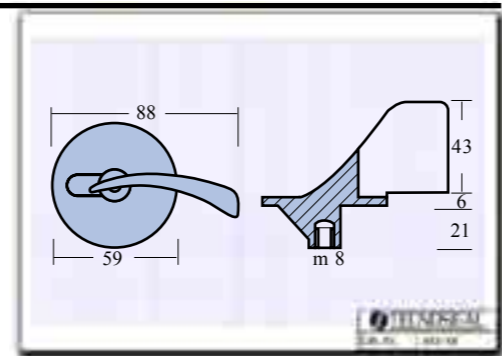

PLACCA PER MOTORI - BASSA • HORSESHOE
SERIE - 100 HP

cod. kg

01907 0,135
2504025*



RONDELLA PER MOTORI • ENGINE WASHER
SERIE - 6 HP

cod. kg

01904 0,010
2504030*

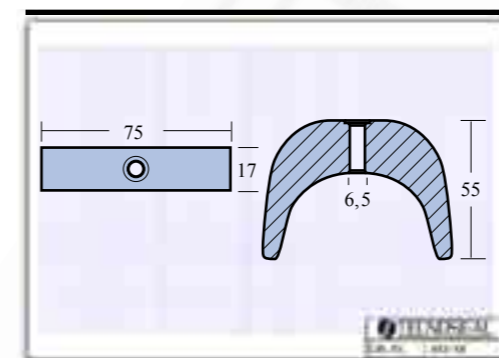
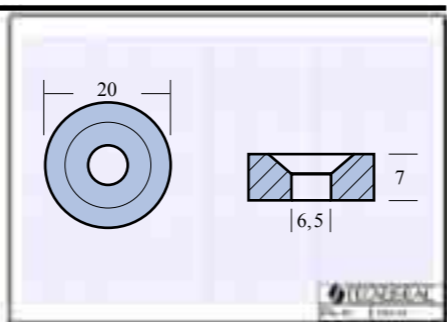

PLACCA PER MOTORI - ALTA • HORSESHOE
SERIE - S405 - S700

cod. kg

01908 0,210
2504020*



* original code

* original code

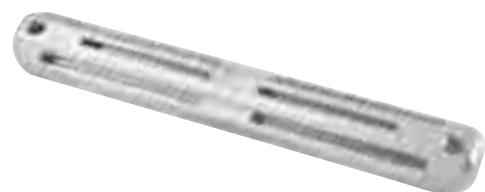

BARRA PER MOTORI • BAR FOR ENGINES
SERIE - S600

cod. kg

01909
2504015* 0,400

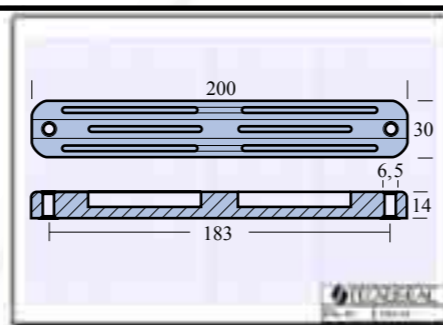

PLACCA MOTORI • HORSESHOE
SERIE - IZMIR 8 CV NAXOS 15 CV

cod. kg

01912
2504035* 0,100

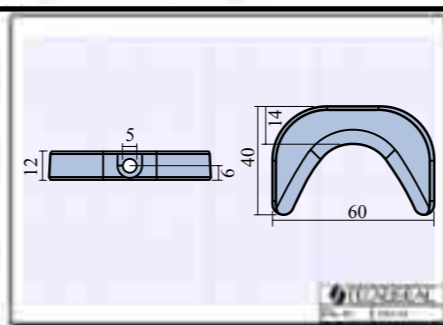

PINNA PER MOTORI • SKEG FOR ENGINES
SERIE - MANTA/BARRACUDA

cod. kg

01913 0,220

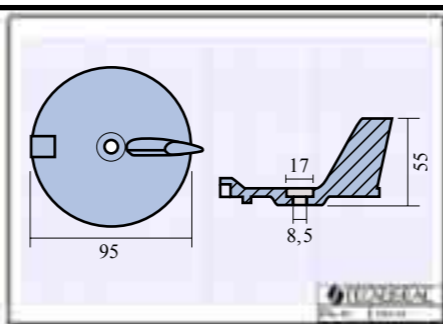

ANODO A CILINDRO PER MOTORI 80/100 HP
ENGINE ANODE 80/100 HP

cod. kg

01914 0,070

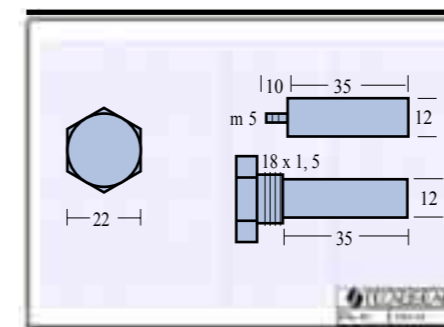
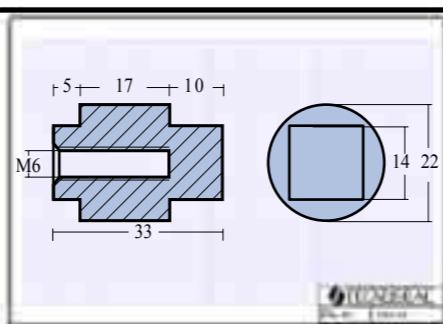

cod. kg

02050T
COMPLETO 0,070

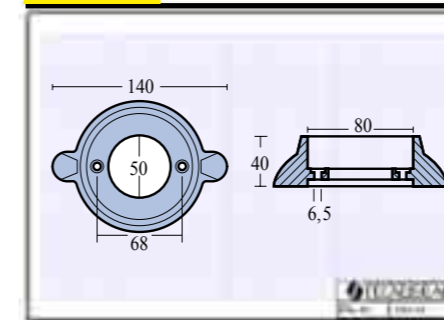

BARROTTO PER MOTORI • ROD FOR ENGINES

cod. l Ø1 Ø2 kg

02050
SOLO ANODO 35 12 M 5 0,030



02050TP
SOLO TAPPO 18X1,5 0,040



COLLARE PER MOTORI • COLLAR FOR ENGINES

cod. kg

02051
24BUKB00E5829* 0,880

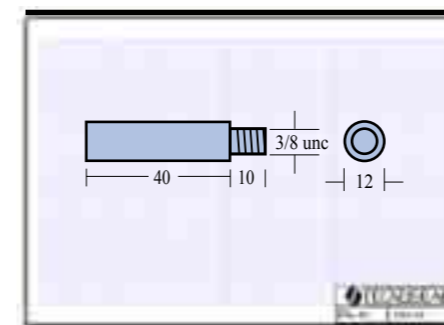

BARROTTO PER MOTORI • ROD FOR ENGINES

cod. Ø1 Ø2 l kg

02052 12 3/8" 40 0,035

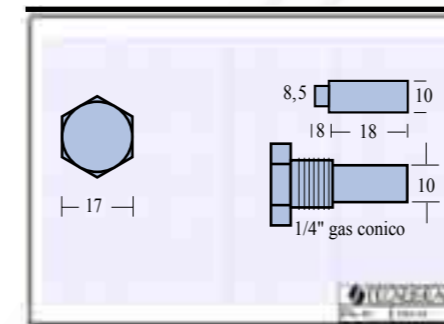

cod. kg

02053T
COMPLETO 0,035

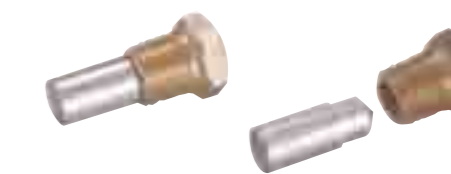

BARROTTO PER MOTORI • ROD FOR ENGINES

cod. l Ø1 Ø2 kg

02053
SOLO ANODO 18 10 8,5 0,015



02053TP
SOLO TAPPO 1/4" GAS CONICO 0,020



* original code

* original code

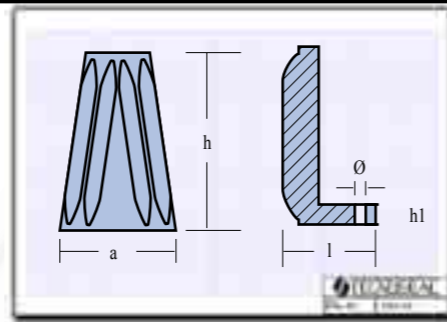
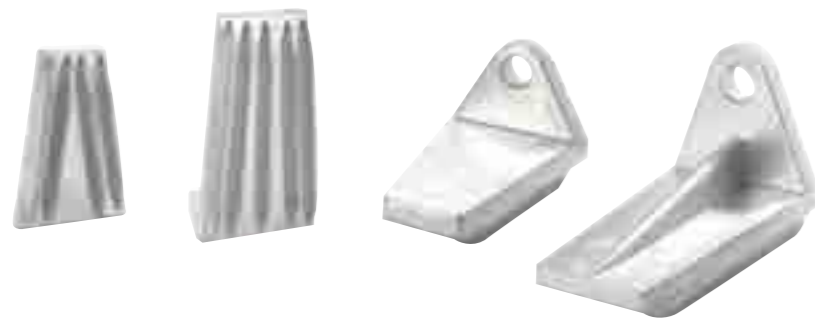

SQUADRE PER MOTORI • BRACKETS FOR ENGINES
SERIE - PICCOLA

cod.	h	h1	a	l	Ø	kg
02400 542.15062.6*	90	11	59	54	12	0,450

SERIE - GRANDE

cod.	h	h1	a	l	Ø	kg
02401 542.16082.4*	120	11	68	77	15	0,820

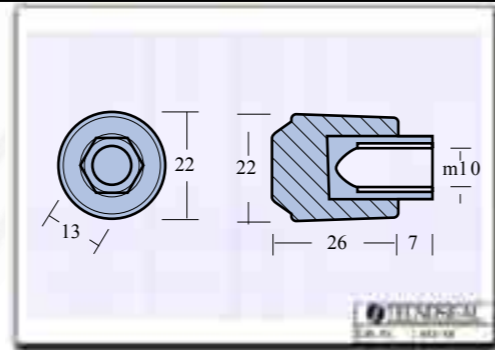

BARROTTO PER MOTORI • ROD FOR ENGINES

cod.	l	Ø	Ø2	kg
02402 590.14055.2*	26	22	10	0,050

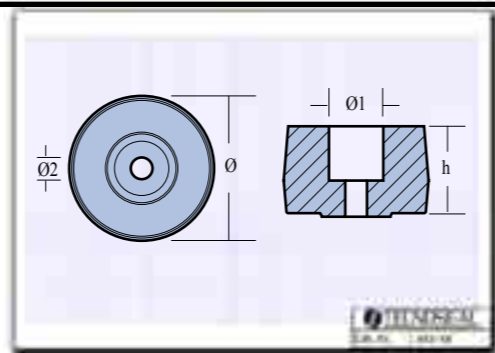

RONDELLE PER MOTORI • ENGINE WASHERS

cod.	Ø	Ø1	Ø2	h	kg
02403/1 590.16324.3*	57	26	10	35	0,480

cod.	Ø	Ø1	Ø2	h	kg
02404	80	30	12	50	1,510

* original code

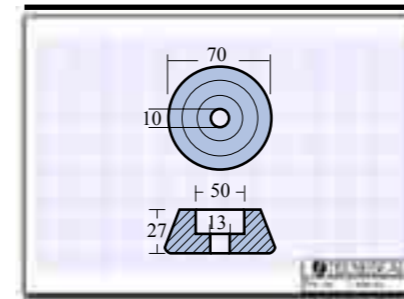

RONDELLA PICCOLA - SMALL ENGINE WASHER

cod.	Ø	h	kg
02450	70	27	0,465

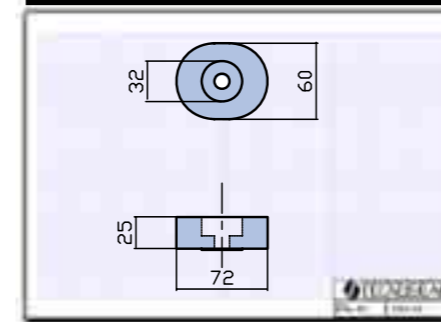

**RONDELLA PER MOTORE KAMEWA
ENGINE WASHER**

JET FF 375S - CLASSE V2000



cod.	kg
02450BIS 10107701*	0,760

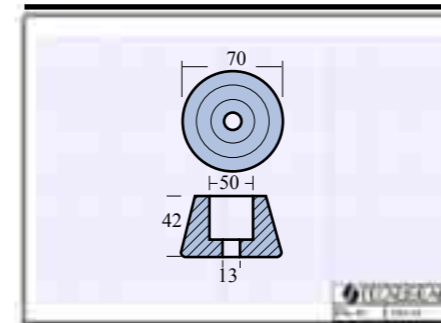

RONDELLA GRANDE - ENGINE WASHER

JET FF 375S - CLASSE V2000

cod.	Ø	h	kg
02451 10108210*	70	42	0,710

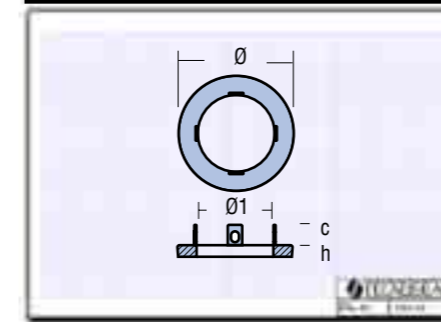

COLLARE CON INSERTI • COLLAR WITH STRAPS

JET FF 375S - CLASSE V2000

cod.	Ø	Ø1	c	h	kg
02452	160	106	23	17	1,350

cod.	Ø	Ø1	c	h	kg
02452 BIS 37517411*	226	126	23	21	3,000

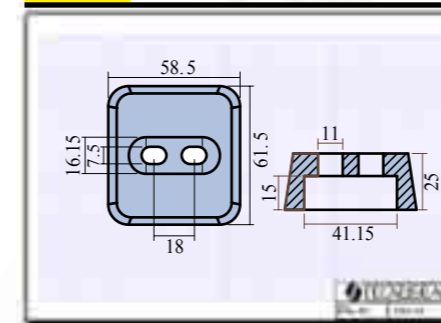

PIASTRA PER MOTORE • PLATE FOR ENGINE

JET FF 375S - CLASSE V2000

cod.	kg
02453 10108220*	0,480

* original code



PIASTRA PER MOTORI • PLATE FOR ENGINES
JET FF 375S - CLASSE V2000

cod. kg

02454
10108230*



2,080

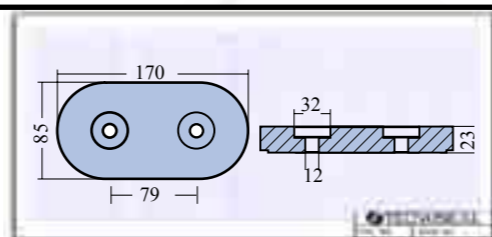

COLLARE • COLLAR
SERIE - A

cod. kg A B C

02455



0,740

78

50

45

02456



0,985

90

60

48

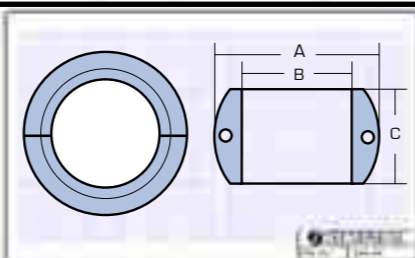

PIASTRA PER MOTORI • PLATE FOR ENGINES
SERIE - TIPO KAMEVA

cod. kg

02457



4,280

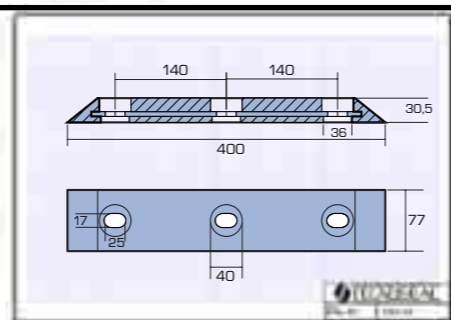

cod. kg

02458



7,3

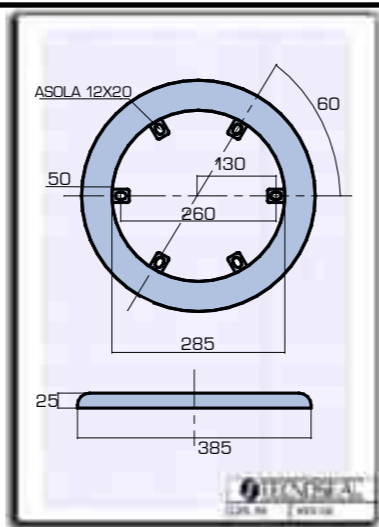

cod. kg

02459



0,75

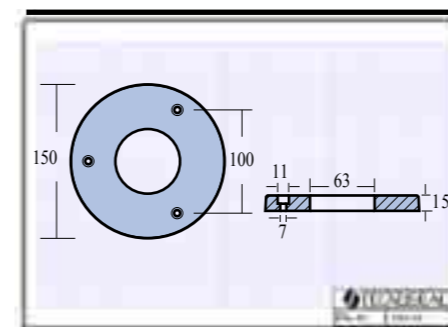
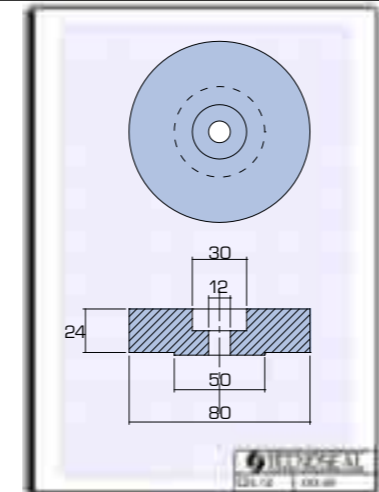

COLLARE PER MOTORI • COLLAR FOR ENGINES

cod. Ø h kg

02501



150

15

1,535

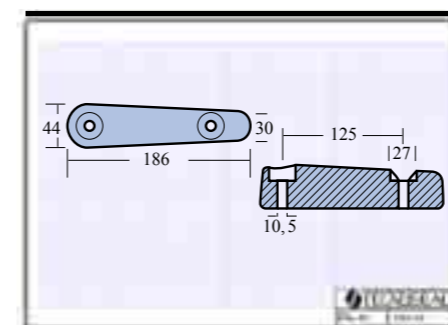

BARRA PER MOTORI • BAR FOR ENGINES
SERIE - GRANDE

cod. kg

02510



1,560

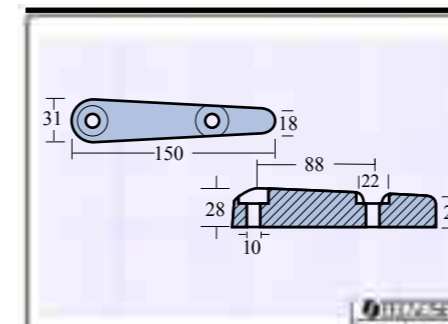

BARRA PER MOTORI • BAR FOR ENGINES
SERIE - PICCOLA

cod. kg

02511



0,540

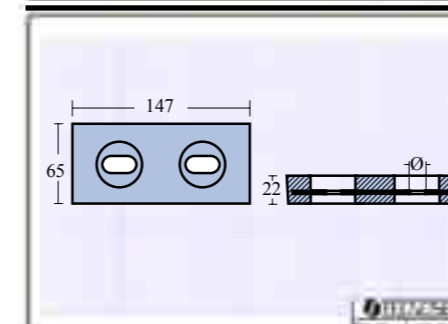

BARRA PER MOTORI
BAR FOR ENGINES
SERIE - RETTANGOLARE

cod. l a h i Ø KG

02512



147

65

22

70

13X25

1,160

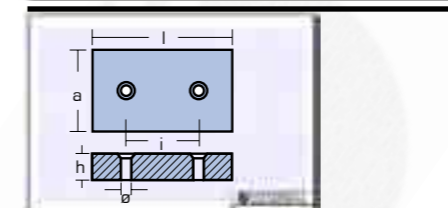

cod. l a h i Ø KG

02513



155

100

20

75

7

1,16

cod. l a h i Ø KG

02514



300

150

26

125

7

8,0

* original code



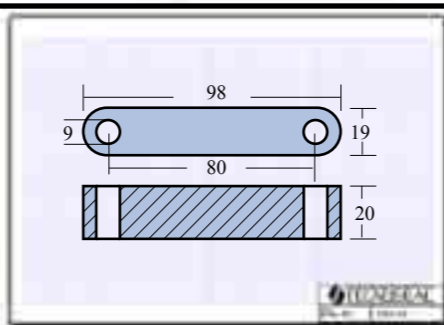

PLACCA OVALE PER MOTORI • OVAL PLATE FOR ENGINES
SERIE - LUNGA - IDROJET 292

cod.	i	kg
02520	80	0,220

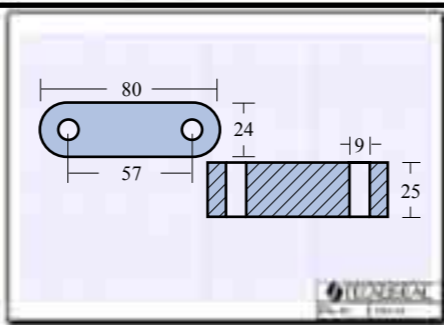

PLACCA OVALE PER MOTORI • OVAL PLATE FOR ENGINES
SERIE - CORTA - IDROJET 292

cod.	i	kg
02521 103359*	57	0,280

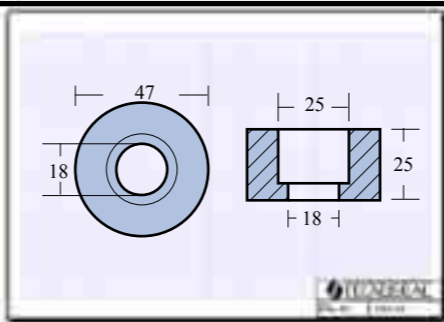

RONDELLE PER MOTORI • ENGINE WASHER

cod.	Ø	kg
02522	47	0,210

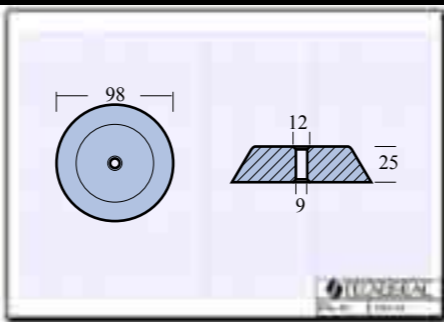

FLANGIA PER MOTORI • FLANGE FOR ENGINES
IDROJET 292

cod.	Ø	kg
02523 102185*	98	1,000

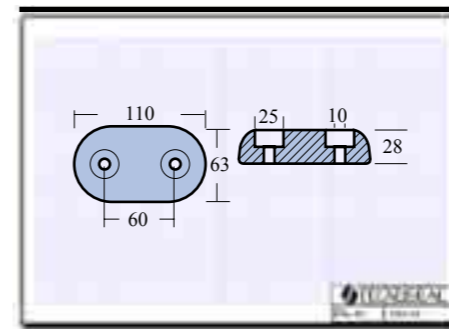

PLACCA PER MOTORI • PLATE FOR ENGINES
IDROJET 292

cod.	l	a	kg
02524	110	60	0,895

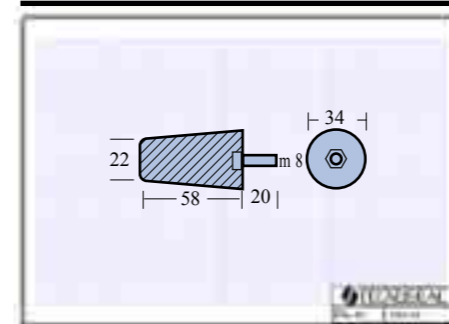

BARROTTO CONICO M8 • CONIC ROD M8
SERIE HAMILTON 912 - IDROJET 292

cod.	kg
02525 111593 111644*	0,255

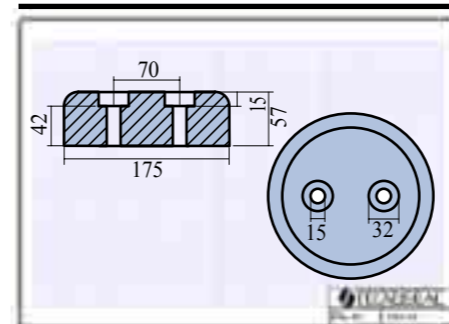

FLANGIA TONDA PER POPPA • STERN ANODE
SERIE - HAMILTON

cod.	kg
02526 103862*	9,140

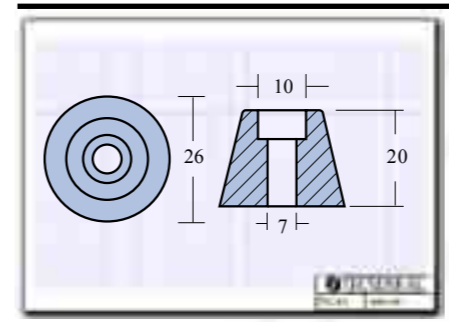
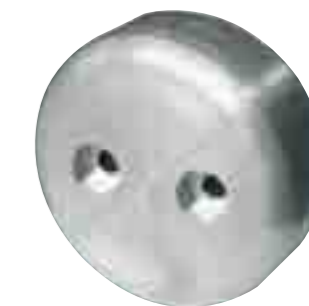

OGIVA TIPO SLEIPNER PER MOTORI SP30/40 4 HP
OGIVES SLEIPNER TYPE

cod.	kg
01050 31180*	0,045

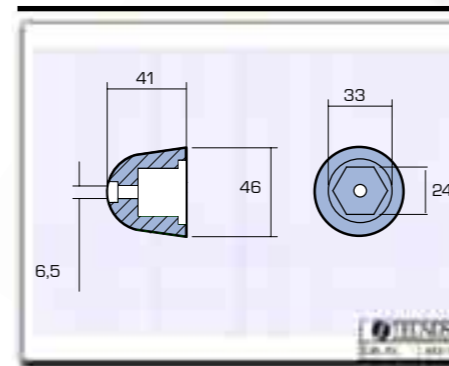

OGIVE PER BOW THRUST • BOW THRUST NUT ANODES
SERIE TIPO SIDE POWER

cod.	kg
02480 201180*	0,245



* original code

* original code

Filtro per Acqua Filter for water

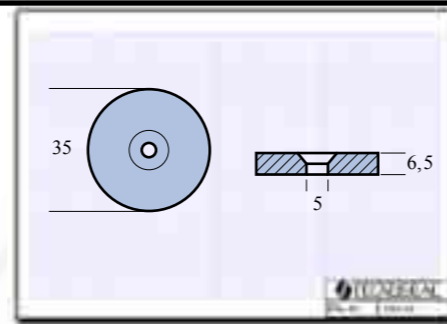

FILTRO PER ACQUA
FILTER FOR WATER

cod.	Ø	kg
02600	35	0,040

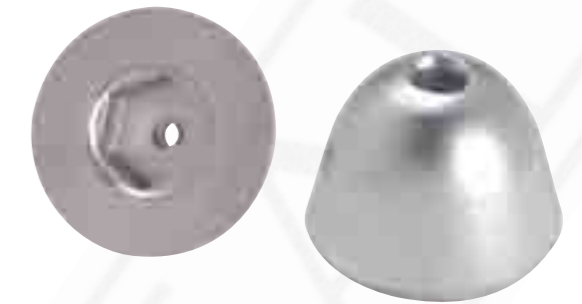
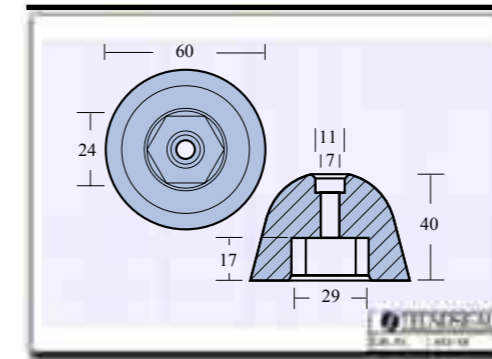

OGIVA ESAGONALE • HEXAGONAL OGIVE
SERIE - Ø 60 H.41

cod.	Ø est	esag	kg
03500 BP195 E*	60	24	0,435



Ogive per bow thrust Bow thrust nut anodes

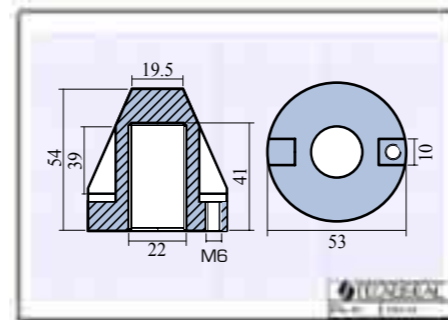

OGIVA PER BOW THRUST • BOW THRUST NUT ANODES
SERIE - AZ.

cod.	kg
03450	0,480

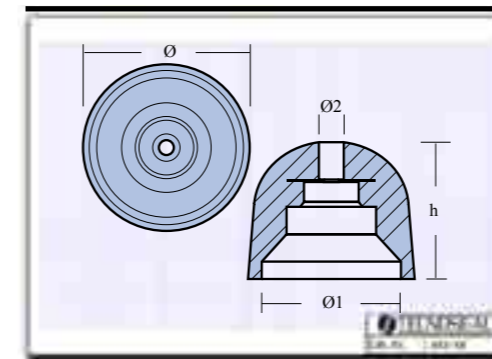

OGIVE CONICHE INSERTO INOX • CONIC OGIVES WITH INOX STRAP
SERIE - Ø 68 H.54

cod.	Ø1	h	Ø	Ø2	kg
03501	56	55	68	6,5	0,635



OGIVE CONICHE INSERTO INOX • CONIC OGIVES WITH INOX STRAP
SERIE - Ø 84 H.52

cod.	Ø1	h	Ø	Ø2	kg
03504	56	52	84	6,5	0,945

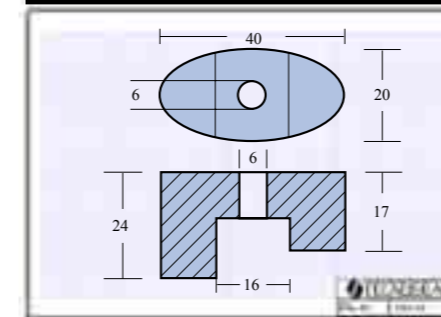

OGIVA PER BOW THRUST • BOW THRUST NUT ANODES
SERIE - BE.

cod.	kg
03451	1,100



PIASTRINA PER BOW PROPELLER • PLATE FOR BOW PROPELLER
SERIE - KW3 - V-SET0153

cod.	kg
03502 BP129*	0,065



* original code



RONDELLA • WASHER
SERIE - VETUS

cod. h Ø kg

03503 45 78 1,050

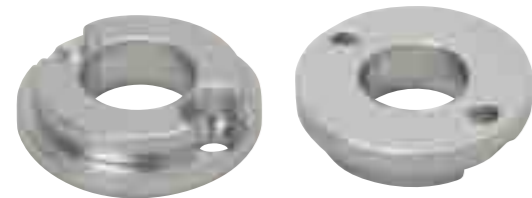
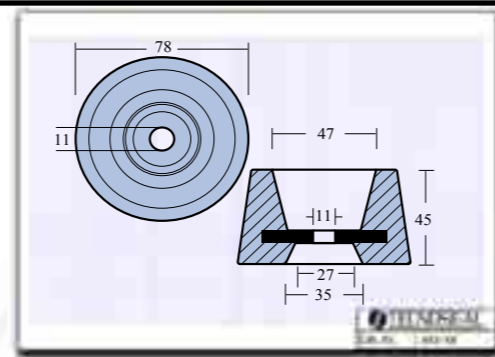

PIASTRINA PER BOW THRUST • WASHER FOR BOW THRUST
SERIE: KGF 25

cod. kg

03505 0,040

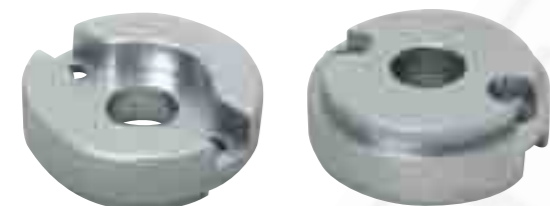
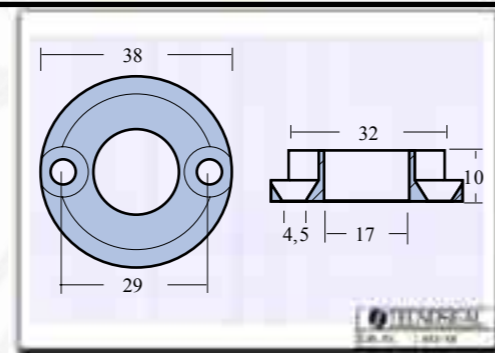

PIASTRINA PER BOW THRUST • WASHER FOR BOW THRUST
SERIE - KGF 35 E 55

cod. kg

03506 0,145

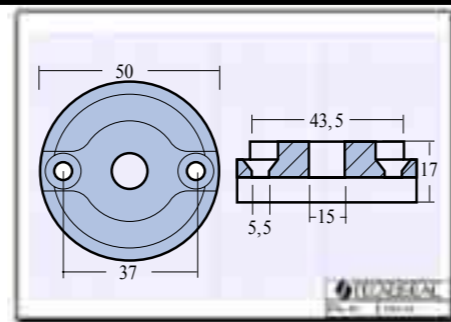

PIASTRINA PER BOW THRUST • WASHER FOR BOW THRUST
SERIE - KGF 75 E 95

cod. kg

03507 0,145

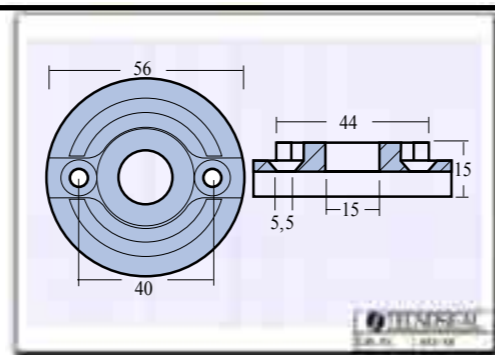

OGIVA ESAGONALE • HEXAGONAL OGIVE
SERIE - Ø 50 H.41

cod. Ø est esag kg

03508 50 24,5 0,380

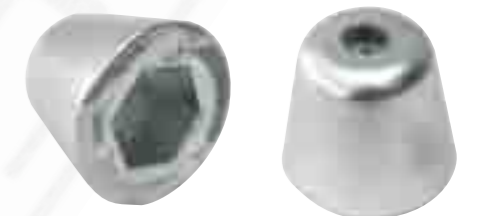
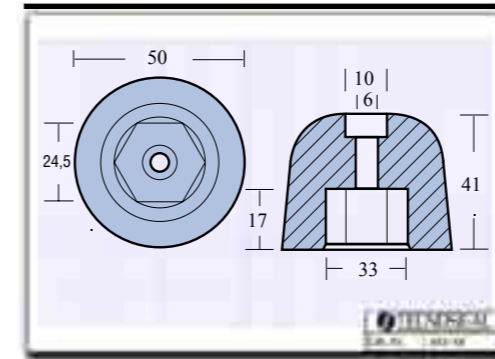

OGIVA • NUT ANODE

cod. kg

03509 0,385

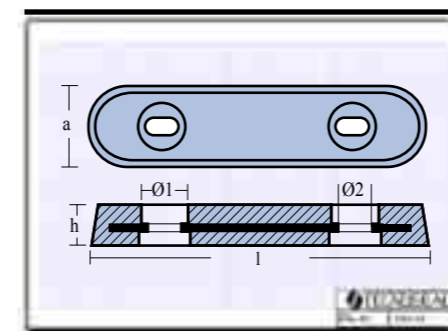
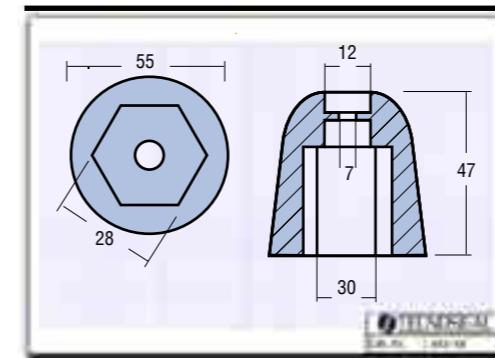

SERIE - VET

cod. l a h i ref.vetus Ø1 Ø2 kg

00220 150 60 25 80 15 27 11x15 1,0

00221 250 63 29 140 25 32 13x25 2,3



cod. l a h i ref.vetus Ø1 Ø2 kg

00222 290 55 30 200 - 32 13x25 2,7

00223 350 72 35 200 35 38 13x25 4,5



* original code

* original code

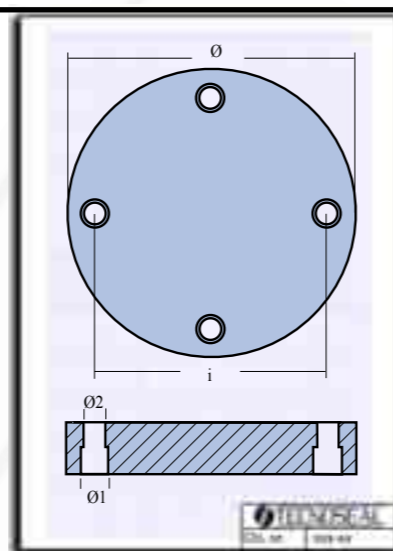

SERIE - TURIAN

cod.	Ø	h	Ø1	Ø2	i	kg
19003	140	25	14	8	110	2,655
19004	135	20	14	8	115	2,050

cod.	Ø	h	Ø1	Ø2	i	kg
19005	125	25	13,5	8	105	2,070

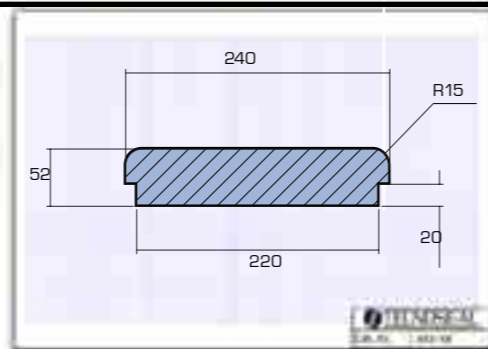

OGIVE • OGIVES
SERIE - TIPO AZIMUT BENETTI

cod.	Ø	kg
19011	240	15,360

A RICHIESTA ALTRI DIAMETRI
OTHER SIZE ON REQUEST

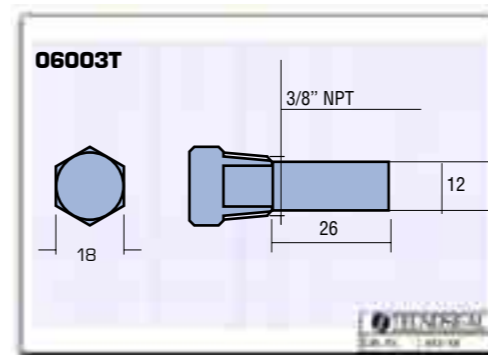
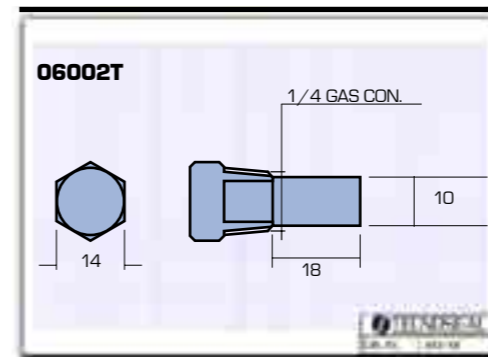

BARROTTO PER INVERTITORE • ROD
SERIE TIPO ZF

Cod.	A	B	C	Ch.	Fil.	Kg
06002T	18	10	10	14	1/4 gas con.	0,030

Cod.	A	B	C	Ch.	Fil.	Kg
06003T	26	12	12	18	3/8 gas con.	0,060

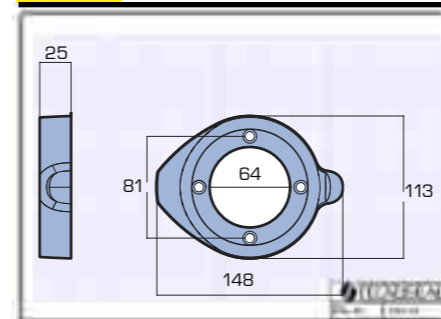

COLLARE PER PIEDE POPPIERO • COLLAR FOR STERN DRIVE
SERIE TIPO ZF

cod.	kg
06004	0,940



PIASTRINA PER MOTORI • PLATE FOR ENGINES

cod.	kg
06001	0,290

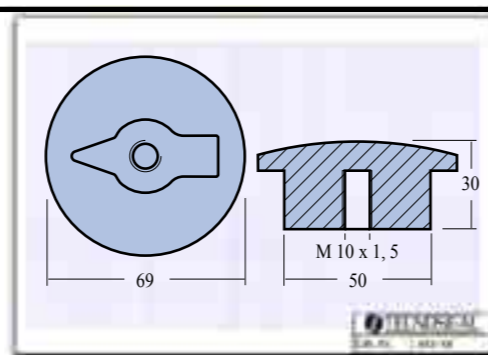



Anodi scambiatori per entro bordo

Entrobordo / Inboard

General Motors

02000 serie 8517480 16 | 54 | 12 | 7/16" unc

02000TP serie 8517479 1/2" gas conico

02001 serie 8515851 19 | 85 | 15 | 5/8" unc

02001TP 3/4" gas conico

02002 serie 8515842 19 | 54 | 15 | 5/8" unc

02002TP 3/4" gas conico

02003 12 | 40 | 10 | 3/8" unc

02003TP 3/8" gas conico

Fpt - Aifo

02010 serie 821 8105277* 14 | 26 | 8 | 12

02010 TP 18 x 1,5 | 24

02010/99 8105277* 13 | 26 | 7 | 10

02010TP/99 18 x 1,5 | 24

02011 serie 828 8210M22* 8101772* 20 | 20 | 11 | 14

02011 TP 28 x 1,5 | 32

02011 TP/98 8210M22* 28 x 1,5 | 27

02012 serie 8361 8105277* 13 | 26 | 8 | 10,1

02012 TP 16 x 1,5 | 24

02013 44/700 interc. 8109743* 10 | 18 | 8 | 7

02013 TP 12 x 1,5 | 17

02014 TP 10 x 1 | 13

02015 TP 10 x 1,25 | 13

02017 serie Cursor 14 | 40 | 10 | m 8

02017TP serie Cursor 18 x 1,5 | 22

* original code

Anodi scambiatori per entro bordo

Entrobordo / Inboard

Caterpillar

02020 serie 3208 14 | 26 | 7 | 12

02021 serie 2283 6L2283* 10 | 55 | 11 | 1/4" unc

02021TP 6L2282* 1/4" gas conico

02021/1 serie 3500 116-7011* 9 | 35 | 11 | 1/4" unc

02021/1 TP 7/16" unf | 14

02022 serie 2016 6L2016* 22 | 20 | 11 | 5/8 UNF

02022TP 6L2020* 3/4" gas

02023 serie 2289 6L2289* 16 | 76 | 13 | 3/8" unc

02023TP 5B9169* 1/2" gas

02024 serie 2288 6L2288* 16 | 63 | 13 | 3/8" unc

02024TP 1/2" gas conico

02025 14 | 33 | 12 | 5/16" unc

02026 serie 2284 6L2284* 28 | 55 | 20 | 3/4" unc

02026TP 6L2286* 1" 1/4 gas conico

02027 serie 2280 6L2280P* 12 | 40 | 10 | 3/8" unc

02027TP 6L2279P* 3/8" gas conico

02028 serie 3412 7E5076* 16 | 41 | 9 | 7/16 unf

02028TP 1/2" gas conico

02029 serie 3126 6L2280G* 12,5 | 38 | 10 | 7/16 unf

02029TP 6L2279G* 3/8" gas

02029/BIS serie 3126 6L3104* 10 | 38 | 11 | 1/4" unc

02029/BIS TP 1149096* 1/4" gas

02030 10 | 30 | 16 | 8

02031 13 | 26 | 15 | 9,5

02032 10 | 31 | 9 | m 8

02033 12 | 40 | 10 | 3/8" unc

* original code

Anodi scambiatori per entro bordo

Cummins



02040  

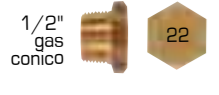

02041 serie 8517474  

02042  



02043  

02043TP  



02044  

02044TP  

Bukh

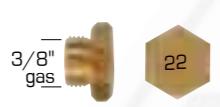
02050  



02050TP  

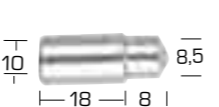

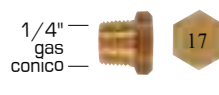
02052  



02053  

02053TP  

VM

02060  

02060TP  

02061  

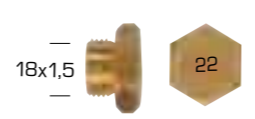
02061TP  

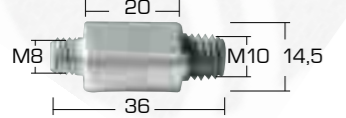

02064  

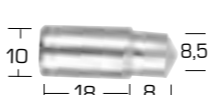

Anodi scambiatori per entro bordo

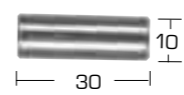
Ford

02070  

02070/A  

02070TP  

02071  

02071TP  

Isotta Fraschini

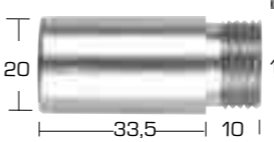
02080  



Renault



02090  

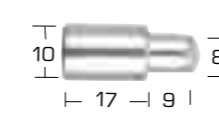

02090TP  

Nanni Mercedes

02100  

02100TP  

02101  

02102  

Mitsubishi

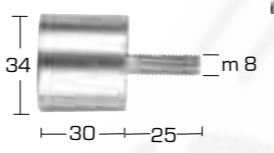
02111  

Scania

02200  

02200TP  

02201  

02201TP  

Anodi scambiatori per entro bordo

Entrobordo / Inboard

Baudouin

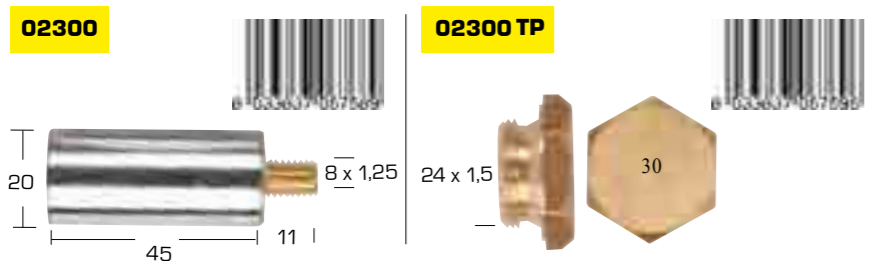

Lombardini

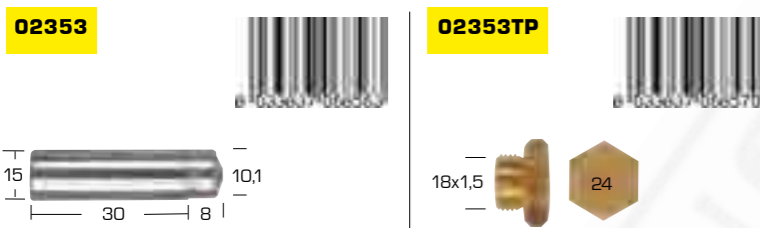

Volvo Penta

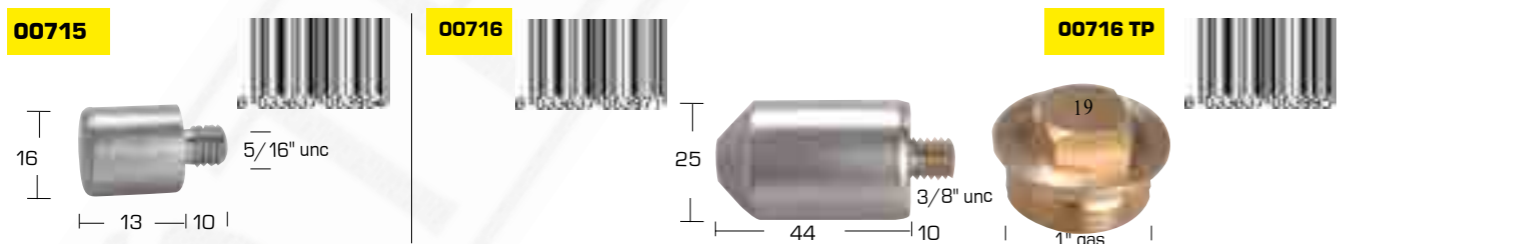
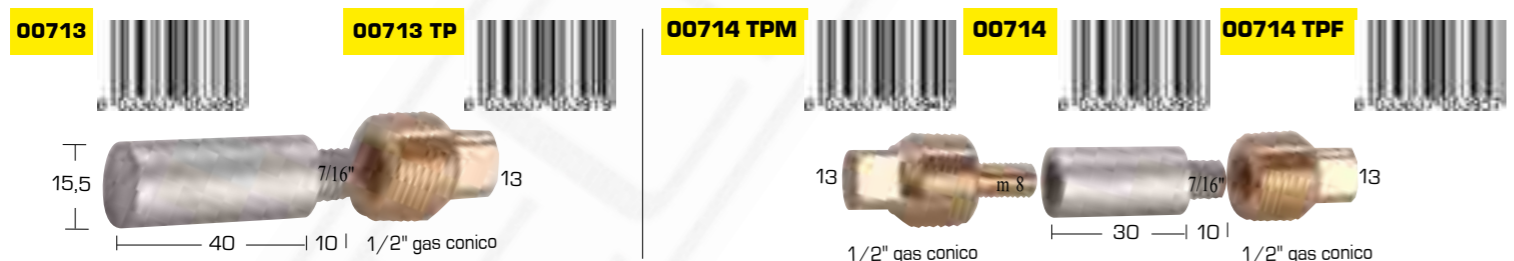

BMW

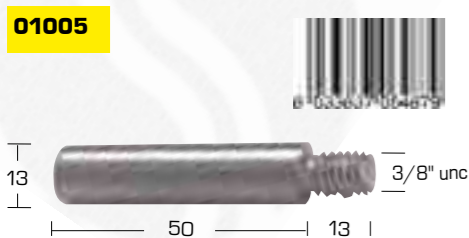

Ruggerini

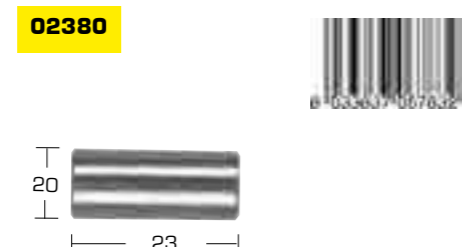

Yamaha

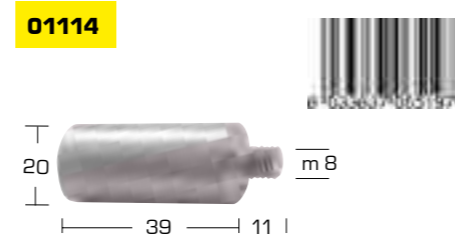

Anodi scambiatori per entro bordo

Entrobordo / Inboard

Castoldi

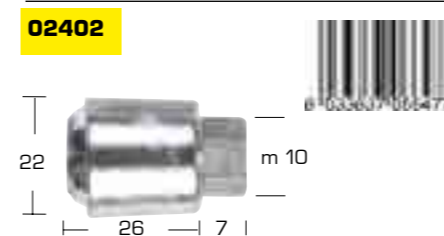

Yanmar

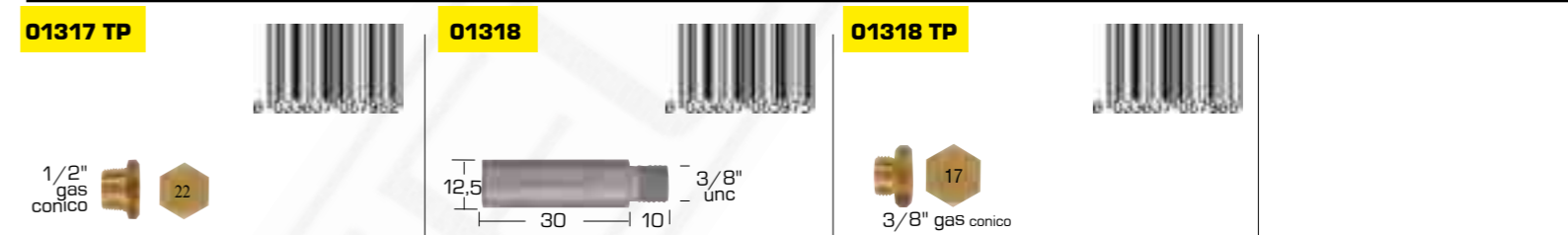
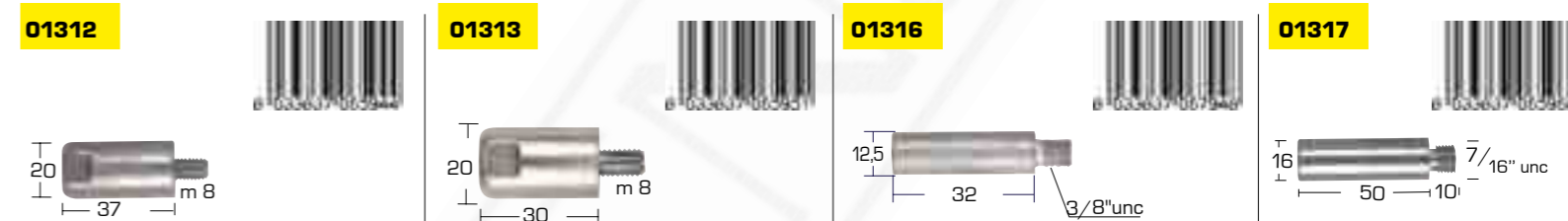

ANELLI DI STRISCIAMENTO

Dall'esperienza consolidata in ambito navale Tecnoseal propone ai suoi clienti il rimedio più efficace per la protezione degli assi elica di trasmissione, l'anello di strisciamento. Questo sistema custom made a seconda della trasmissione è composto da un anello che ha subito un bagno d'argento per aumentarne la capacità di conduzione e che viene stretto all'asse da proteggere. Sopra l'anello viene montato un porta spazzole alla cui estremità vengono montate delle spazzole di grafite. A differenza dei normali bracciali l'anello di strisciamento viene facilmente montato nella parte asciutta dell'asse all'interno dell'astuccio prima delle tenute il che permette anche di verificarlo in modo agevole periodicamente. Il meccanismo del porta-spazzole viene collegato attraverso un cavo di massa all'anodo di poppa dedicato. Quindi la funzione dell'anello è quello di potenziare la sua protezione anodica attraverso i suoi materiali (ottone e argento) attirando le correnti galvaniche provenienti sia dall'estremità dell'asse che dall'interno del motore, scaricarle attraverso le spazzole di grafite all'anodo di zinco dedicato.

I benefici sono molteplici:

- Nessun peso sull'asse.
- Maggiore carica anodica grazie all'argento e quindi maggiore protezione.
- Maggiore durata dell'anello rispetto ai tradizionali bracciali o collari che vanno sostituiti annualmente e che spesso si perdono prima del rimessaggio.
- Semplice cambio delle spazzole di grafite.

PROPELLER SILVER SHAFT GROUNDING

Thanks to its long experience in the naval field, Tecnoseal offers to its customers the most efficient solution for the protection of the transmission shaft propeller: the propeller silver shaft grounding.

This system, can be customised according to the transmission type, is composed by a ring that is silver bathed to increase the conductivity and which is tightened to the axis to protect. On the ring it is fitted a brush-holder with graphite brushes at its end. The propeller silver shaft grounding is installed in the dry part of the axis before the seals, this makes easier its periodic check. The brush-holder is connected to the dedicated stern anode by a ground cable. The ring's function is to increase the cathodic protection of the system thanks to the brass and silver made frame able to attract the galvanic currents coming both from the axis end and from the motor, unloading them by the graphite brushes to the dedicated zinc anode.

The advantages are as follows:

- Minimum weight on the axis
- Better electrical conductivity of the silver made construction and so higher protection.
- Longer duration of the ring, compared to the usual shafts which are replaced every year and that could be consumed before the refitting.
- Easy replacement of graphite brushes



**ANELLI DI STRISCIAMENTO
PROPELLER SILVER SHAFT GROUNDING**

**ANELLI DI STRISCIAMENTO
PROPELLER SILVER SHAFT GROUNDING**

cod.	Ø	h	s	kg	cod.	Ø	h	s	kg
07000	45	60	1,5	0,130	07110	110	50	3,0	0,536
07050	50	60	1,5	0,144	07120	120	50	3,0	0,570
07070	70	50	3,0	0,396	07130	130	40	4,0	0,642
07090	90	50	3,0	0,442	07170	170	40	4,0	0,850
07100	100	50	3,0	0,474					

Altre misure su richiesta. Disponibilità di spazzole e portaspazzole di ricambio
Other sizes on request. Brushes and brush-holders available as spares

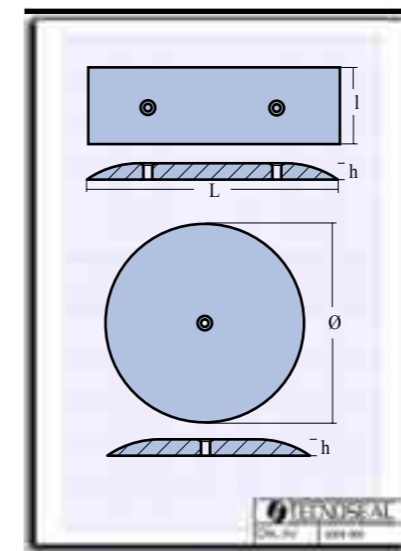

PIASTRE DI MASSA POROSA

La piastra di massa porosa è un dispositivo installato sulla chiglia per scaricare la massa di apparati elettrici (es. frigo) o apparecchiature elettroniche (es. radiotelefono) o l'impianto satellitare ed in particolar modo il parafulmine. Indispensabile per il buon funzionamento di questi strumenti, la piastra di massa è essenzialmente costituita da una tavoletta di bronzo dorato e sinterizzato che viene fissata sotto la carena per mezzo di viti speciali e opportunamente collegata all'apparecchiatura.

Estremamente importante è ricordare che queste piastre non fungono e né sostituiscono gli anodi sacrificali, ma il loro impiego è sempre associato all'utilizzo di questi.

GROUND PLATES

The plate of porous material is a device installed on the keel to discharge the mass of electrical appliances (eg fridge) or electronic equipment (eg mobile phone) or satellite system and particularly the lightning rod. It is essential for the proper running of these instruments, the plate mass is essentially composed of a of gilded bronze and sintered tablet to be fixed under the hull using special screws and properly connected equipment.

It is extremely important to remember that these plates do not act nor replace the sacrificial anodes, but their use is always associated with using them.



**PIASTRE DI MASSA POROSA
GROUND PLATES**

cod.	L	I	h	Superf./Surface	cod.	L	I	h	Superf./Surface
PMseaground 0	155	51	13	1.00 m ²	PMseaground 2	300	80	13	3.00 m ²
PMseaground 1	206	65	13	1.80 m ²	PMseaground 4	455	150	13	8.00 m ² CON QUATTRO FORI - WITH FOUR HOLES
PMseaground 3	Ø		h						

ZINC SPRAY

Le bombolette Zinc Spray della Tecnoseal forniscono il rivestimento migliore per accessori subacquei, ancore, catene, ecc.

Tecnoseal Zinc spray tanks give the best re-coating for underwater equipment, anchors, chains, etc.



Silver Zinc Spray

PURE ZINC SPRAY

cod.	
TEC-ZS1	Ad alto contenuto di Zinco - High Zinc content
TEC-ZS2	Formula standard - Standard formula





PROTECT TEST



Una valigia completa di tester per il controllo del potenziale elettrico, sonda in cloruro d'argento ed altri accessori per verificare l'effettiva protezione di una imbarcazione o struttura metallica a mare. Grazie a tale strumento si possono eseguire in modo rapido le seguenti verifiche:

- Misura della attività della corrosione su strutture marine immerse e su strutture interrate;
- Verifica dell'efficienza della protezione catodica fornita da anodi sacrificali per individuare eventuali interventi di manutenzione;
- Identificazione di aree prive della protezione catodica in un impianto esistente.

Uno strumento indispensabile per cantieri, navi ed armatori.

PORTABLE TEST INDICATOR

A portable cathodic protection tester including a silver chloride probe and other accessories able to check the effective protection of a boat or other submerged structures.

Thanks to this tool it is easier to check the following aspects:

- the corrosion level of submerged and underground installations
- the efficiency of the cathodic protection provided by the sacrificial anodes and the eventual need of maintenance
- if some areas of an already existing installation need a cathodic protection.

A necessary tool for any shipyard, navy and shipowner

PERNI DI FISSAGGIO

TECNOSEAL provvede su richiesta perni e bulloni di fissaggio per tutti i suoi prodotti quali flange, piastre, ogive e bracciali.

FIXING BOLTS

TECNOSEAL supplies on request fixing bolts and nuts for all its anodes as rudders, plates, ogives and shafts



THE GUARDIAN



THE GUARDIAN è l'unità di registrazione più piccola al mondo che ha la capacità di rilevare e registrare costantemente l'entità della corrosione presente sul vostro scafo.

Le applicazioni del THE GUARDIAN sono molteplici. Nella versione FREE si possono ottenere registrazioni per un breve periodo e grazie ad un sofisticato software di brevetto Tecnoseal, il nostro staff tecnico può evidenziare, grazie alle sue registrazioni, in quali momenti lo scafo viene corrosato e di conseguenza offrire soluzioni al riguardo con una adeguata consulenza.

Nella versione PERMANENT è possibile installare una sonda a scafo permanente e rilevare costantemente le eventuali corrosioni attraverso un monitor dedicato, installato sia in sala macchine che in plancia, o direttamente nel pannello digitale di controllo in plancia. **Disponibile anche nella versione REMOTE CONTROLLING di monitoraggio a sistema remoto con avvisi mezzo GSM.**

THE GUARDIAN, un vero guardiano a difesa del tuo scafo, oltre a darti la sicurezza mentre sei in navigazione, ti offre sicurezza e garanzia nel mantenimento e nella vendita o acquisto di uno scafo usato. Di vero interesse per i cantieri di nuova costruzione come accessorio indispensabile per la sicurezza dell'imbarcazione.



THE GUARDIAN - C.P REGISTER 95

The C.P. Register 95 is the world's smallest recording unit, which has the capacity to memorize and record constantly the grade of corrosion on the hull of your boat.

The guardian has several applications:

In the FREE version, you can get a short period records; by a hightech Tecnoseal software our technical staff is able to know when the hull is corroded and allow to find and provide the appropriate solutions.

In the PERMANENT version, it is possible to install a permanent hull probe to reveal constantly the eventual corrosion trough a monitor placed in the machine room and in the captain room or directly in the digital panel control of the captain room.

It is also available as remote control system with alert by GSM.

The C.P. Register 95 is a real guardian defending your hull; it gives you a guarantee during navigation, and provides you more benefits when selling your boat and when purchasing a second hand one. It is an interesting tool for any boatbuilder as a boat safety necessary device.

IMPIANTI DI PROTEZIONE CATODICA A CORRENTE IMPRESSA

Tecnoseal srl da molti anni progetta, costruisce ed installa impianti di protezione catodica attiva a corrente impressa per scafi di metallo o protezione di strutture a mare come palancolati di banchine nelle aree portuali e piattaforme marine ed industriali, sealines e pipelines.

L'esperienza comprovata negli anni e la qualità Tecnoseal srl è un marchio di sicurezza e garanzia negli anni per tutta la nostra clientela.

IMPRESSED CURRENT SYSTEMS FOR CATHODIC PROTECTION

Since many Tecnoseal has been designing and manufacturing impressed current systems for naval and industrial applications like aqueducts, submerged pipes, offshore, platforms, sealines, pipelines etc.

The quality of the Tecnoseal brand and the experience of our company is a real guarantee for all our customers.



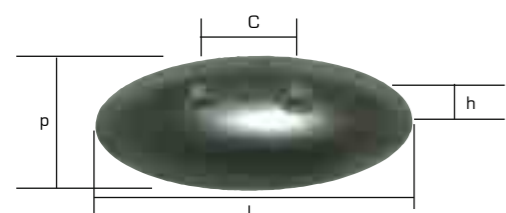

cod.	l	h	p	C	Ø	Kg
TEC-24	112	53	19	31,6	6,6	0,325

cod.	l	h	p	C	Ø	Kg
TEC-25	232	83	17	97,2	7,2	1,625

cod.	l	h	p	C	Ø	Kg
TEC-30	156	67	15,5	120	7	0,970

cod.	l	h	p	C	Ø	Kg
TEC-40	190	70	13	45	7	1,000

cod.	l	h	p	C	Ø	Kg
TEC-DIVERS	305	152	13	140	102x13	3,525

cod.	l	h	p	C	Ø	Kg
TEC-DIVERS-S	152	102	13	66	45x11	1,100

cod.	l	h	p	C	Ø	Kg
TEC-ZHC-2	145	67	19	70	20x15	1,080

NEW!

cod.	l	h	p	C	Kg
00341	300	30	150	150	10

NEW!

cod.	l	h	p	C	Kg
00349	355	118	160	122	10

cod.	l	h	p	C	Ø	Kg
TEC-ZHC-3	159	70	19	67	30x16	1,010

cod.	l	h	p	C	Ø	Kg
TEC-ZHC-5	200	99	19	111	25x15	2,145

cod.	l	h	p	C	Ø	Kg
TEC-Z404	232	83	17	-	12,7	1,625

cod.	l	h	p	C	Ø	Kg
TEC-Z406	213	104	27	126	13	3,050

cod.	l	h	p	C	Ø	Kg
TEC-20	84	45	14	34	7	0,180

cod.	l	h	p	C	Ø	Kg
TEC-21	136	58	14	41	8,8	0,350

cod.	l	h	p	C	Ø	Kg
TEC-DOK	81	32	10	46	6,5	0,155

NEW!

cod.	l	h	p	Kg
00390	220	60	370	24





*“L’arte migliore è quella in cui la mano,
la testa e il cuore di un uomo procedono in accordo”.*

John Ruskin



*“Fine art is that in which the hand,
the head and the heart of man go together”.*

John Ruskin

THE TECNOSEAL WORLD:

PROTEZIONE CATTODICA ATTIVA E PASSIVA SETTORE NAUTICA, PESCA, NAVALE, AREE PORTUALI, INDUSTRIALI E CIVILI.

ACTIVE AND PASSIVE CATHODIC PROTECTION FOR YACHTING, FISHING, NAVAL, PORTS, INDUSTRIAL AND CIVIL SECTORS

PRODUZIONE ANODI SACRIFICALI IN ZN, AL E MG.

SACRIFICIAL ANODES PRODUCTION IN ZINC, ALUMINUM AND MAGNESIUM.

CONSULENZA PER DISPOSIZIONE ANODICA SU NUOVE COSTRUZIONI NAUTICHE E NAVALI.

CONSULTING FOR ANODES POSITIONING ON NEW BOATS AND SHIPS

PROGETTAZIONE, INSTALLAZIONE E MANUTENZIONI DI IMPIANTI A CORRENTE IMPRESSA E MONITORAGGIO PONTILI.

DESIGN, INSTALLATION AND MAINTENANCE FOR IMPRESSED CURRENT SYSTEMS AND PIERS PROTECTION REMOTE MONITORING.

RICERCA E SVILUPPO.

RESEARCH AND DEVELOPMENT.

TECNOSEAL - 58100 Grosseto - via genova 6 - Italy - Tel +39 0664 453702 - Fax +39 0664 453704
info@tecnoseal.com - www.tecnoseal.it

ANODES